

King Post Truss Joinery Analysis Case Study

Timber Frame Engineering Council Symposium
Burlington, VT
August 8, 2013

John Treybal, PE

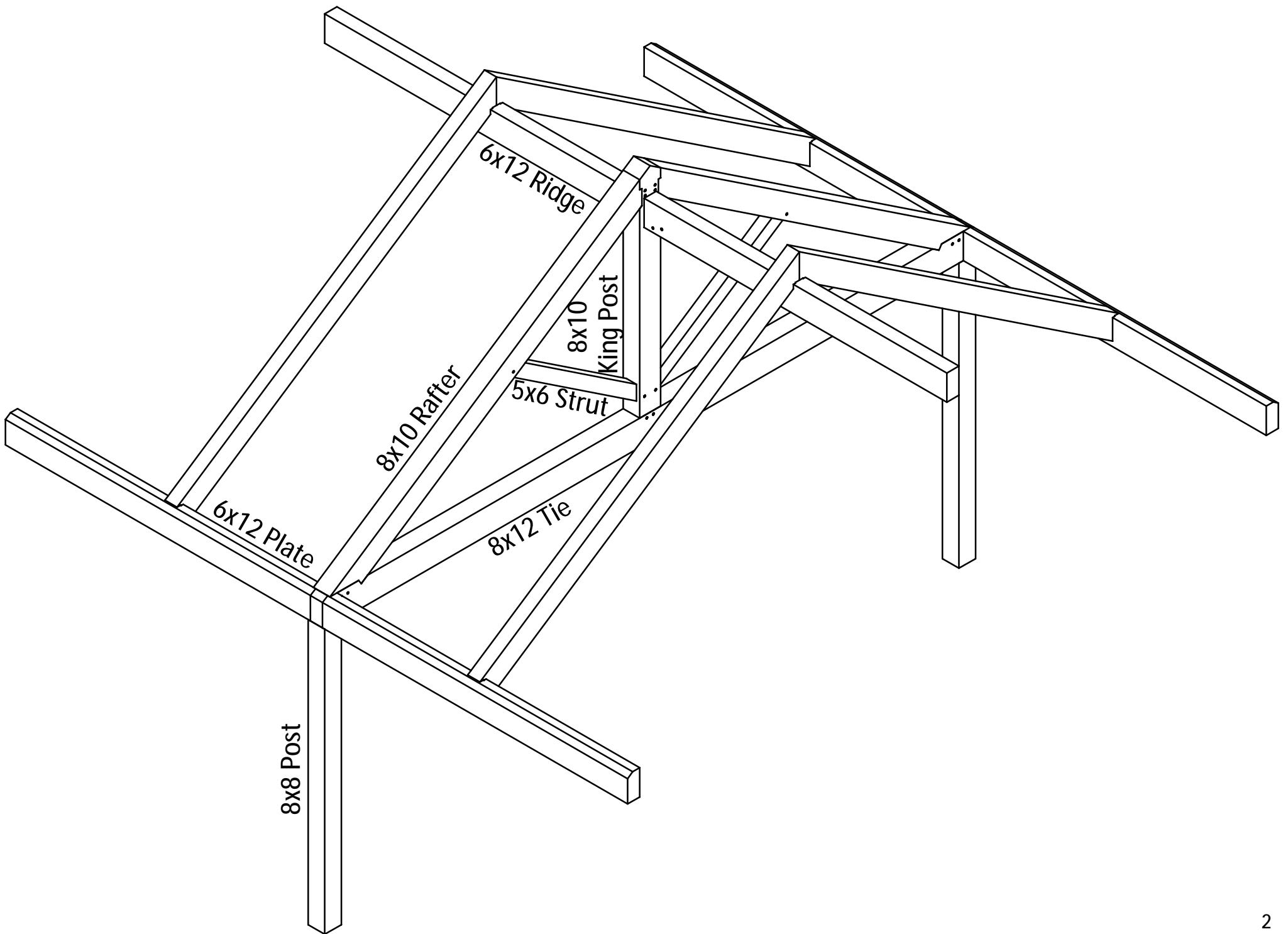



Truss Loading

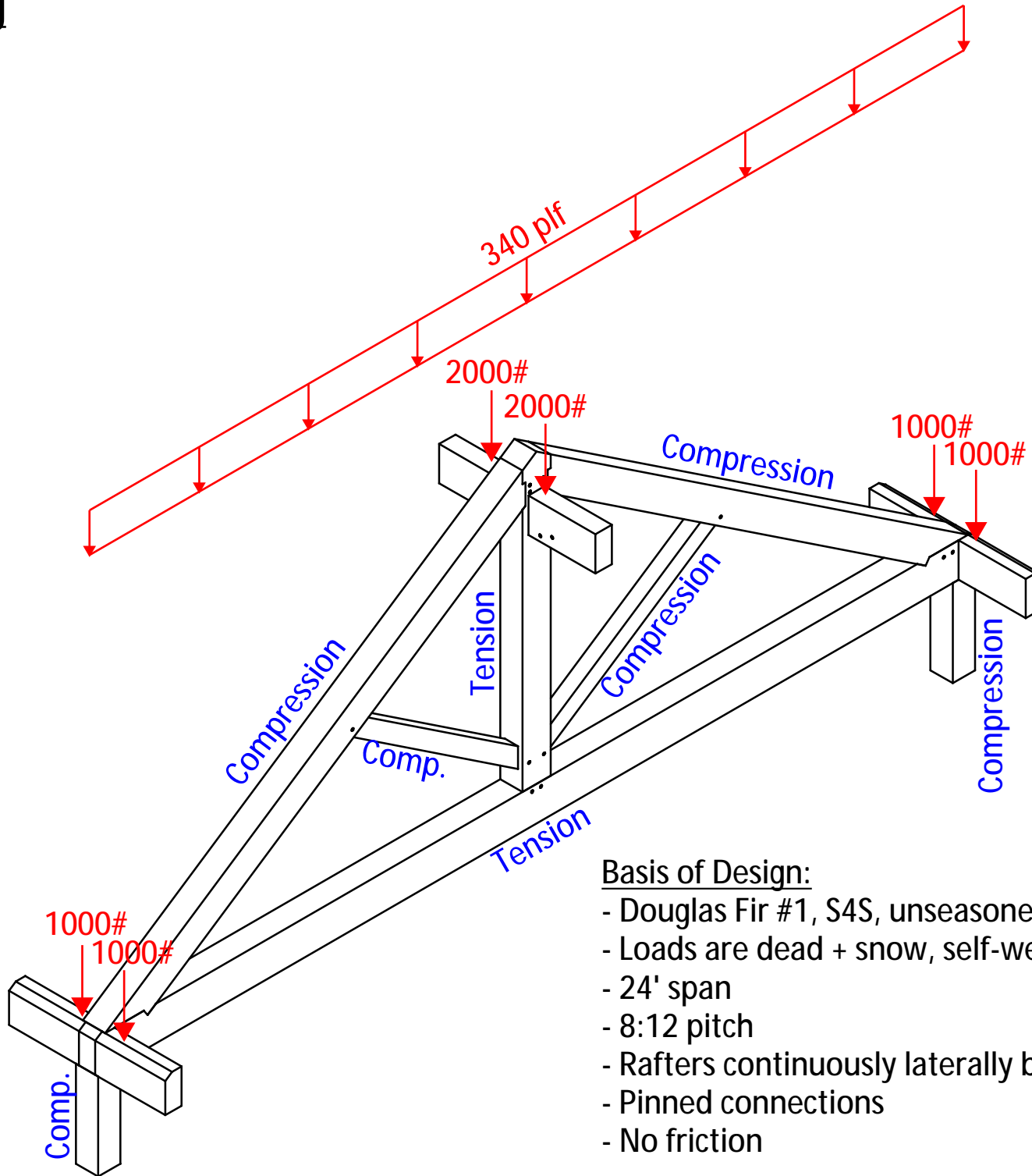

Basis of Design:

- Douglas Fir #1, S4S, unseasoned
- Loads are dead + snow, self-weight included
- 24' span
- 8:12 pitch
- Rafters continuously laterally braced
- Pinned connections
- No friction

Strut / Rafter Joint

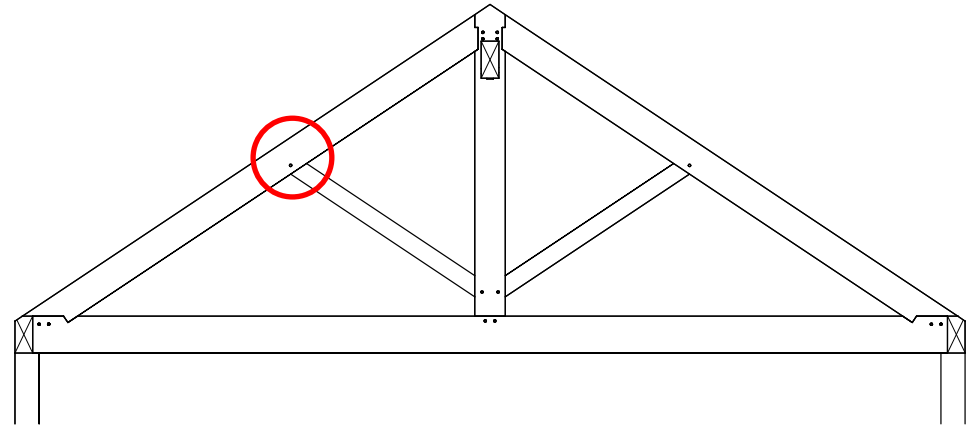
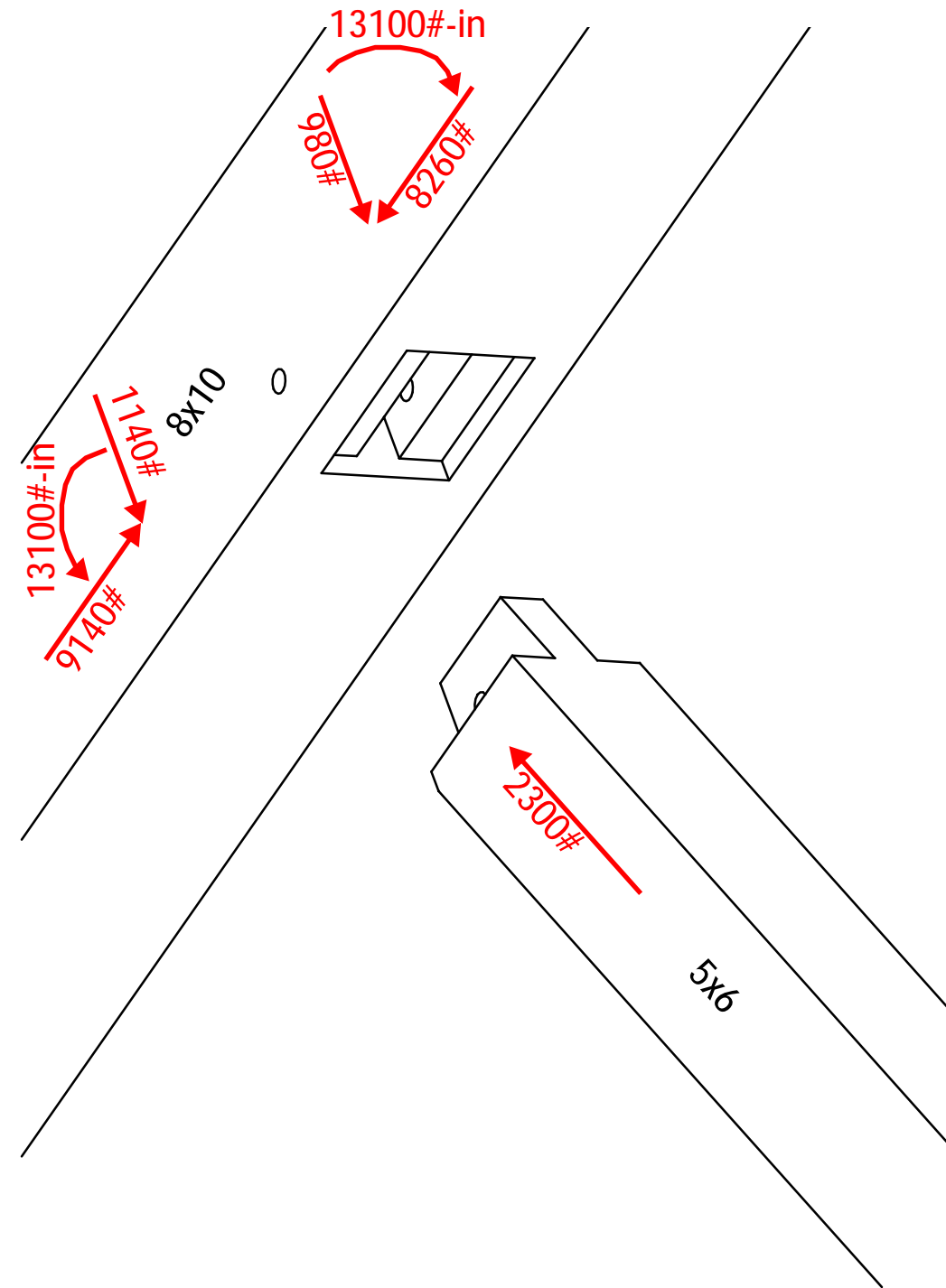

Strut / Rafter Joint

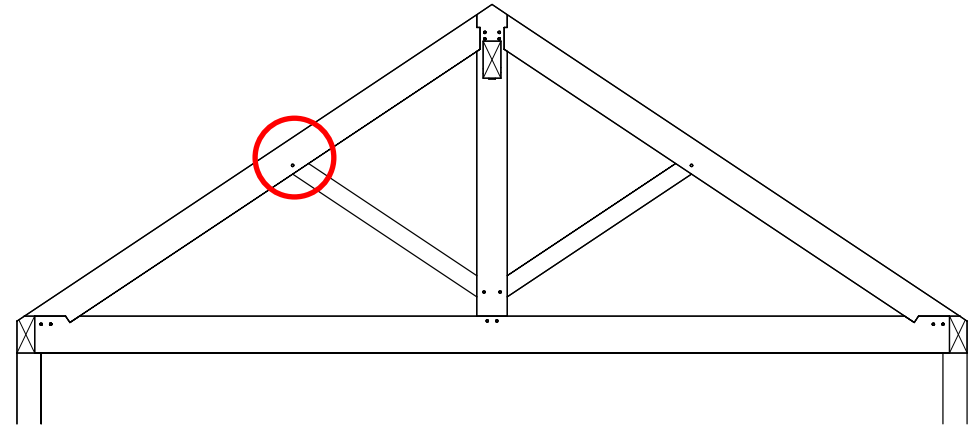
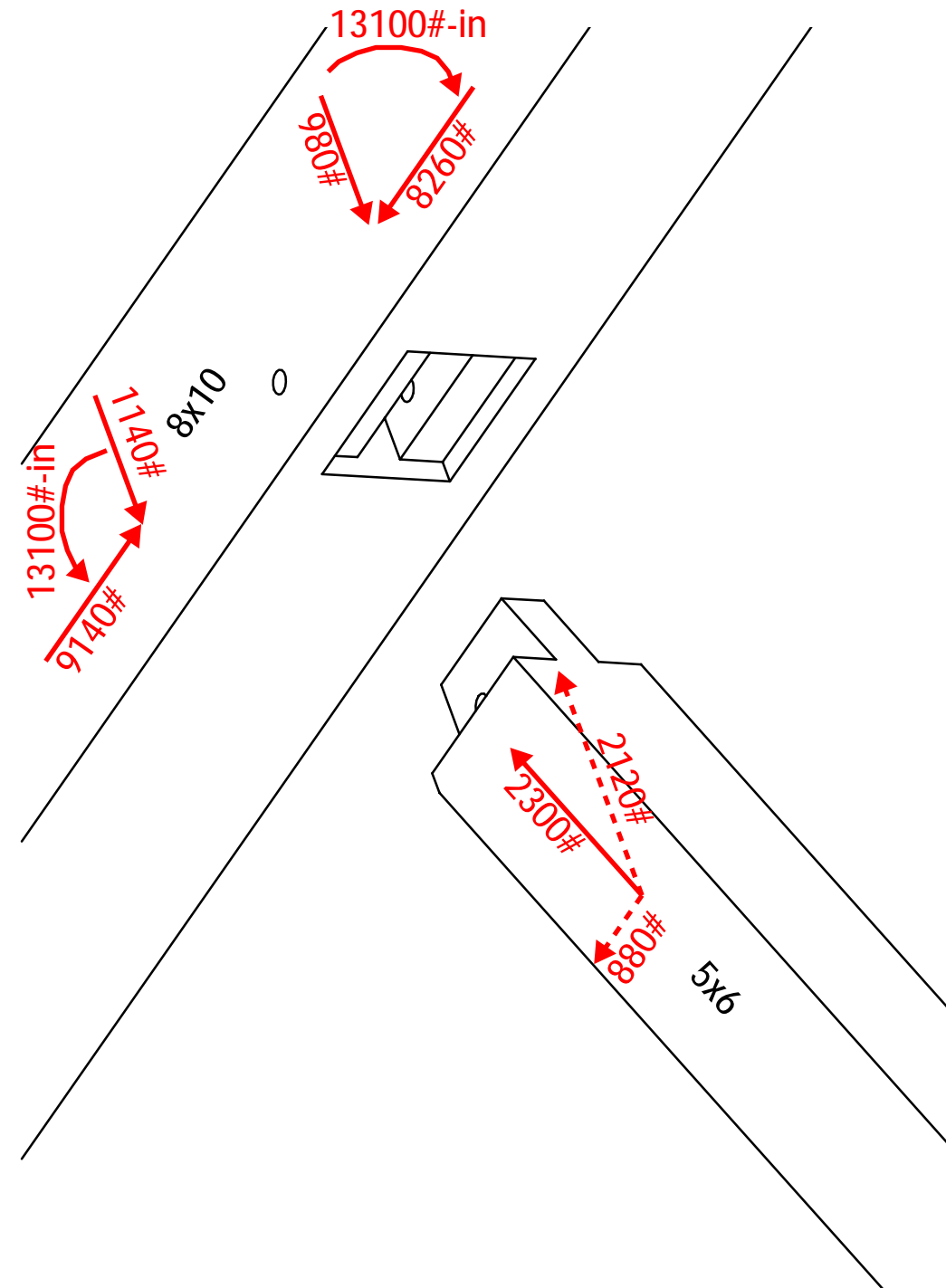

Failure Modes:

- Rafter Bearing on Strut
- Bending and Compression in Rafter at Reduced Section

Strut / Rafter Joint -
Rafter Bearing on Strut (Check 1)

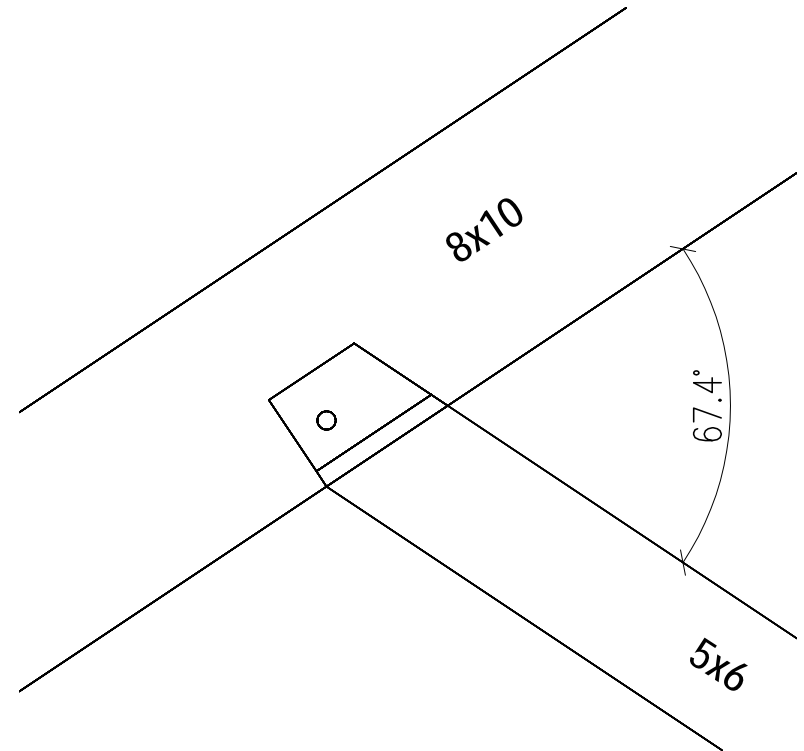
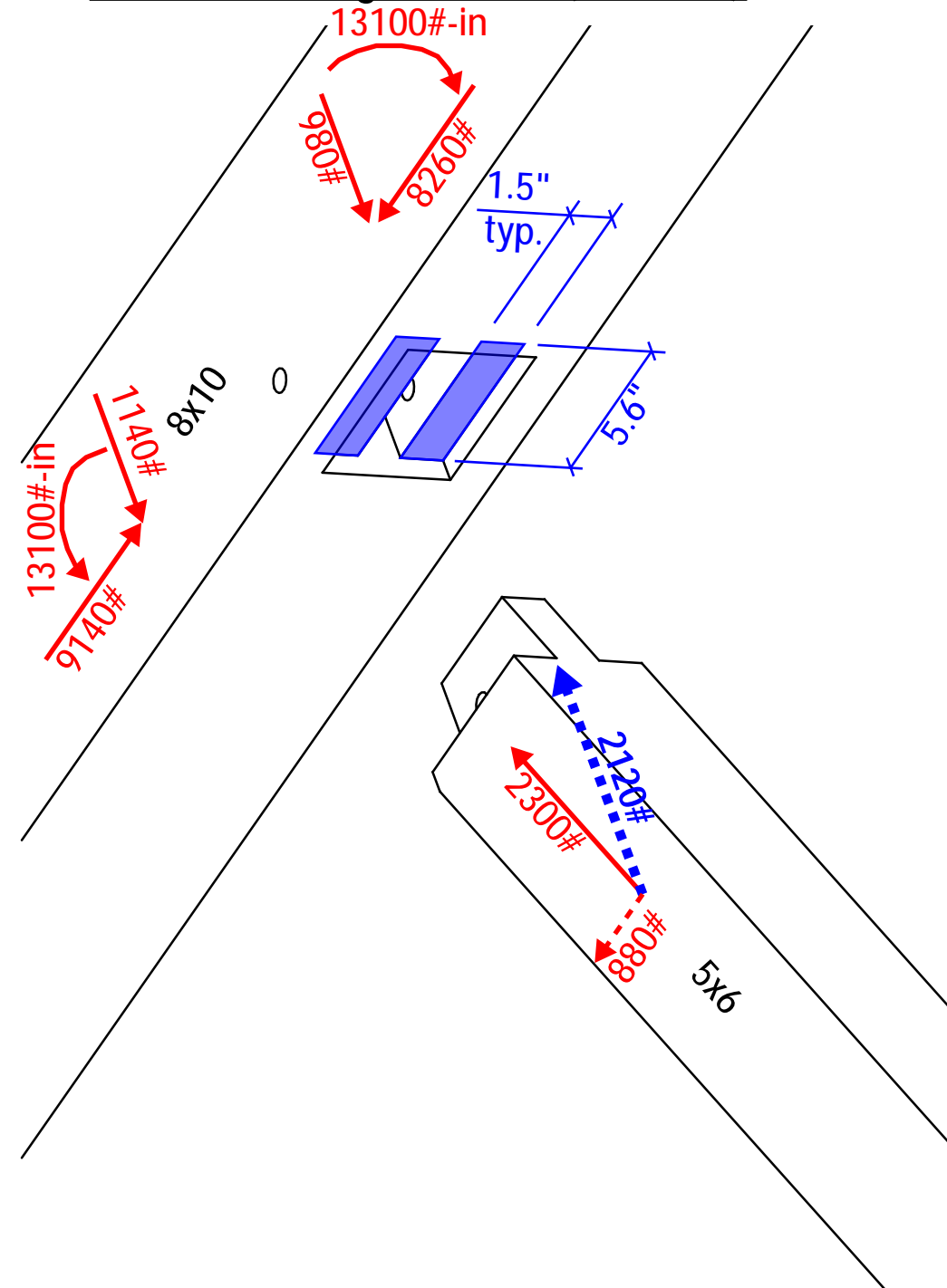

$$f_c = \frac{C}{A} = 126 \text{ psi}$$

$$C = 2,120\#$$

$$A = (1.5" * 5.6") * 2 = 16.8 \text{ in}^2$$

F'_c

$$= \min. \begin{cases} F'_{22.6^\circ \text{ strut}} = 1,020 \text{ psi (Hankinson)} \\ F'_{c \perp \text{ rafter}} = 625 \text{ psi} \end{cases}$$

$$= \boxed{625 \text{ psi} > 126 \text{ psi} \therefore \text{OK}}$$

Strut / Rafter Joint -
Rafter Bearing on Strut (Check 2)

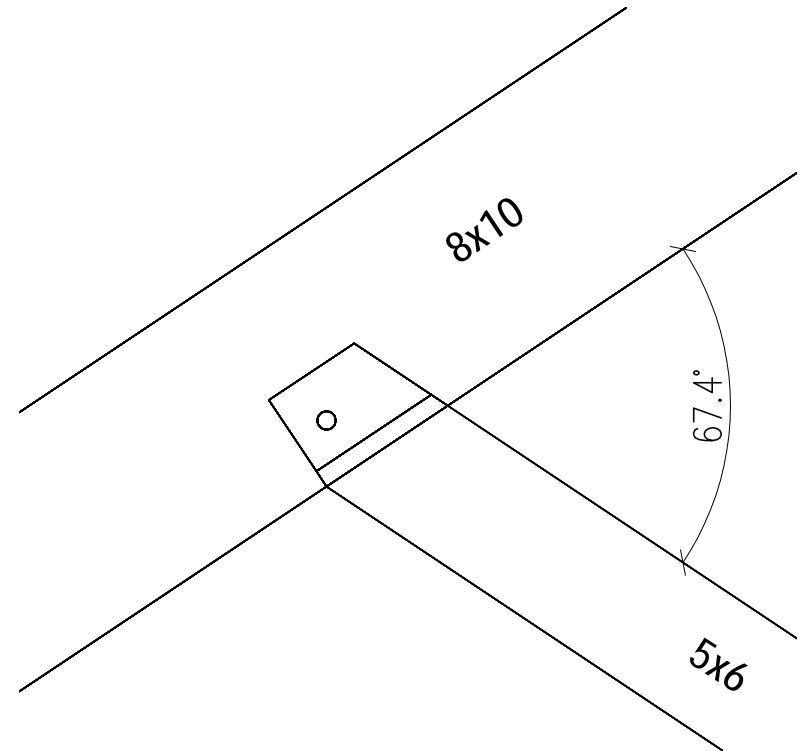
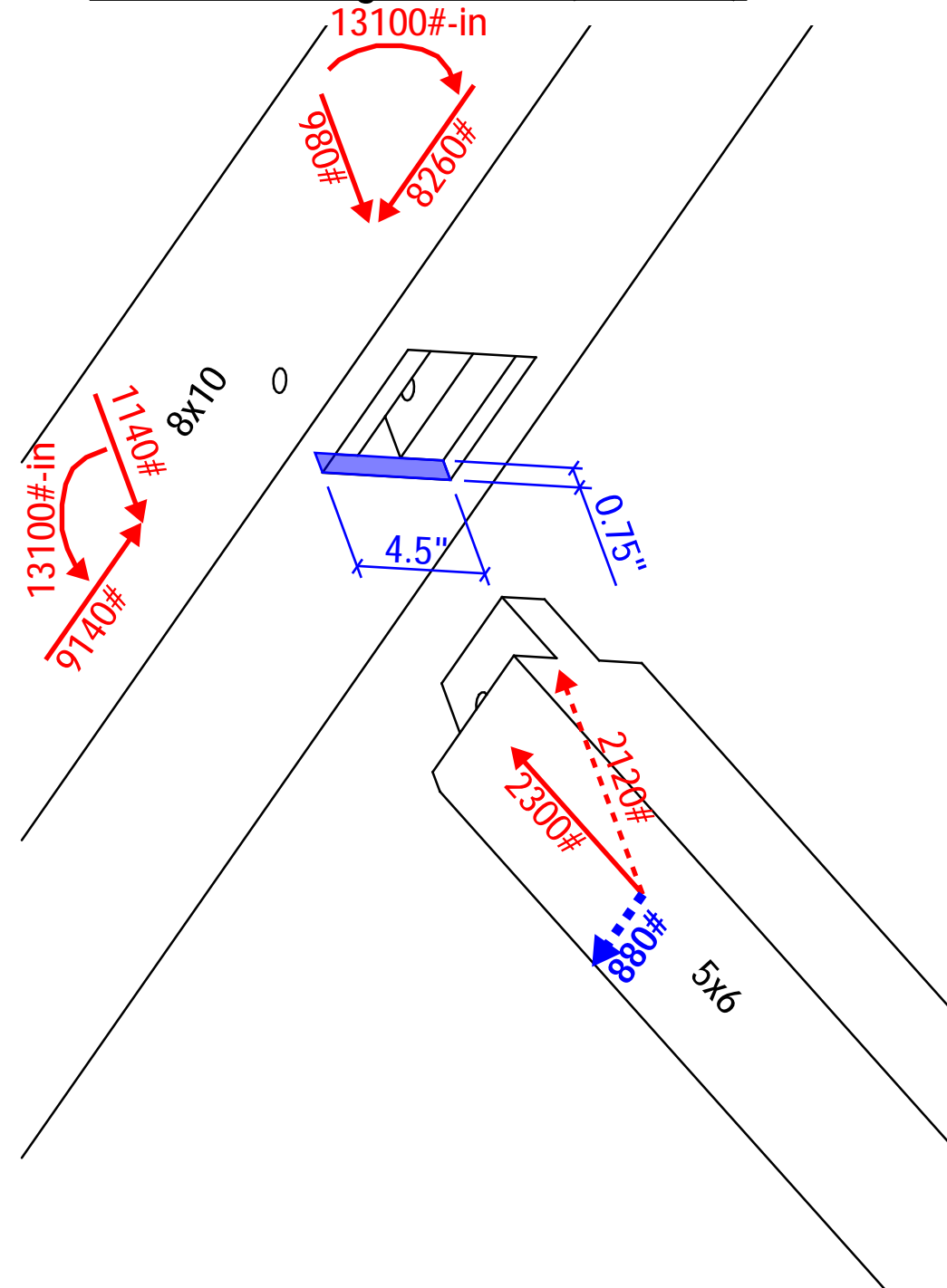

$$f_c = \frac{C}{A} = 260 \text{ psi}$$

$$C = 880\#$$

$$A = 0.75" * 4.5" = 3.38 \text{ in}^2$$

Conservatively ignoring tenon bearing – some might argue for using half of it or more

$$F'_c = \min. \begin{cases} F'_{67.4^\circ \text{ strut}} = 670 \text{ psi (Hankinson)} \\ F'_{c \text{ rafter}} = 1,000 \text{ psi} * 1.15 = 1,150 \text{ psi} \end{cases}$$

$$= \boxed{670 \text{ psi} > 260 \text{ psi} \therefore \text{OK}}$$

Strut / Rafter Joint - Bending and Compression in Rafter at Reduced Section

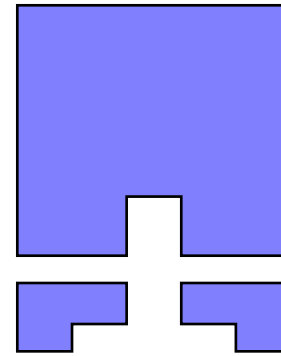
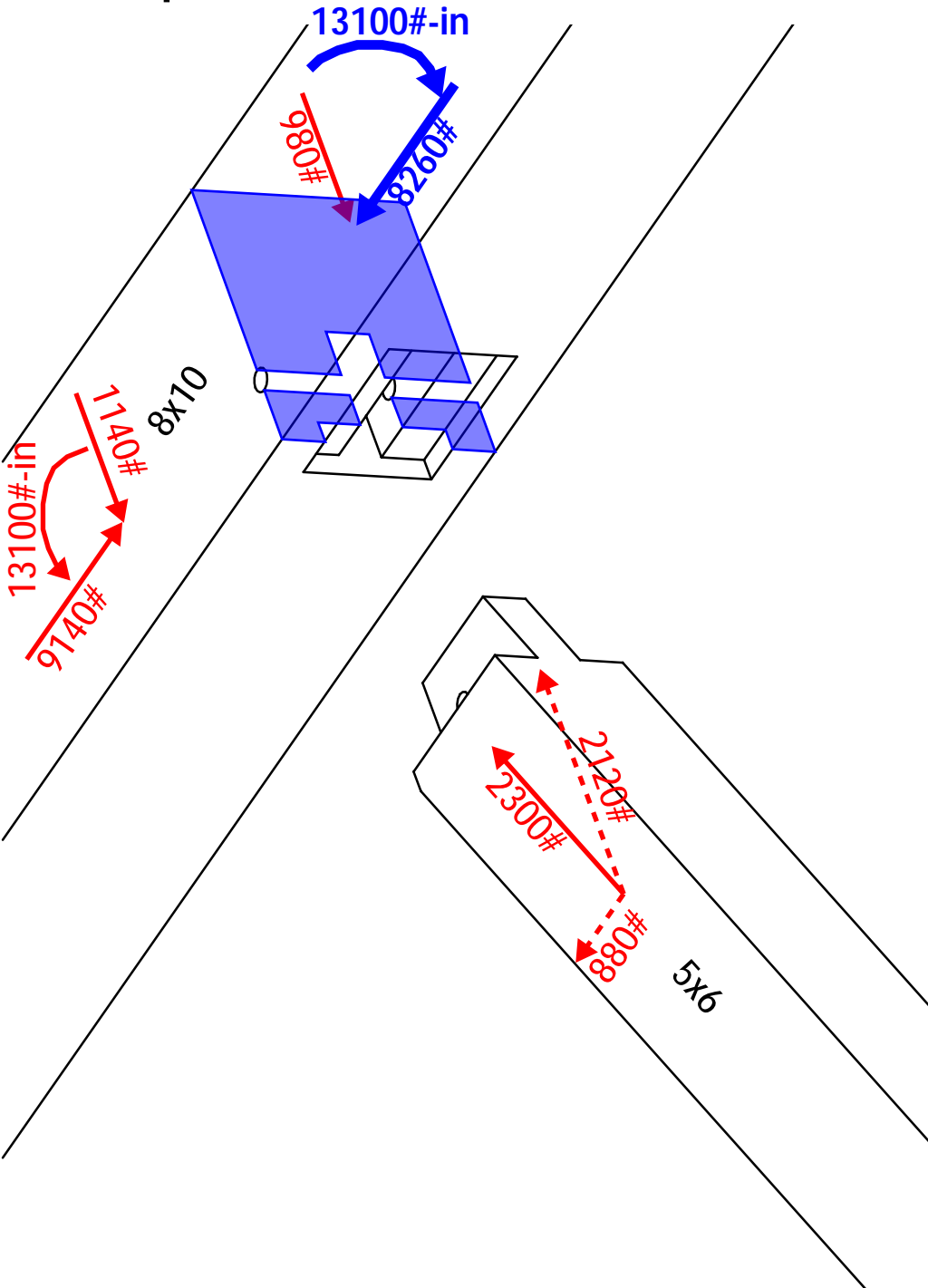

Rafter Net Section Properties:

$$A = 58.1 \text{ in}^2$$

$$S = 71.5 \text{ in}^3$$

Compression Only:

$$f_c = \frac{C}{A} = \frac{8,260\#}{58.1 \text{ in}^2} = 142 \text{ psi}$$

$$F'_c = 1,000 \text{ psi} * 1.15$$

$$= \boxed{1,150 \text{ psi} > 142 \text{ psi} \therefore \text{OK}}$$

Bending and Axial Compression Interaction:

$$\left(\frac{f_c}{F'_c}\right)^2 + \left(\frac{f_b}{F'_b}\right) = \boxed{0.15 < 1.0 \therefore \text{OK}}$$

$$f_b = \frac{M}{S} = \frac{13,100\# - \text{in}}{71.5 \text{ in}^3} = 183 \text{ psi}$$

$$F'_b = 1,200 \text{ psi} * 1.15 = 1,380 \text{ psi}$$

Strut / King Post Joint

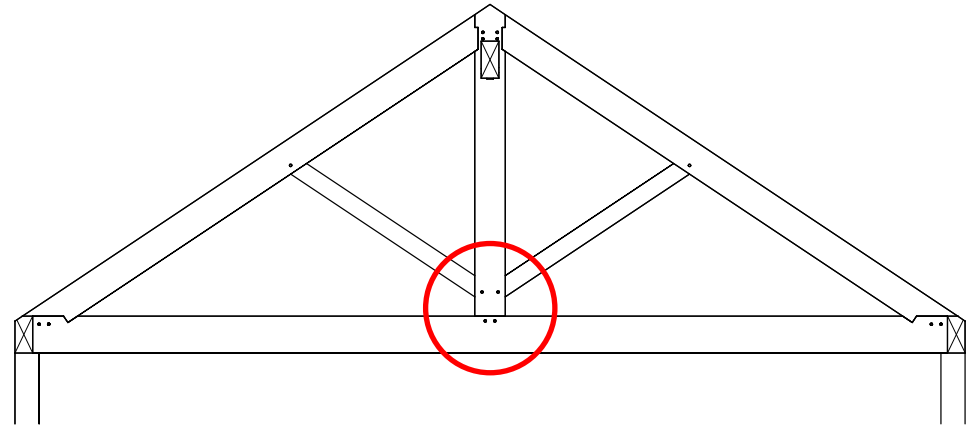
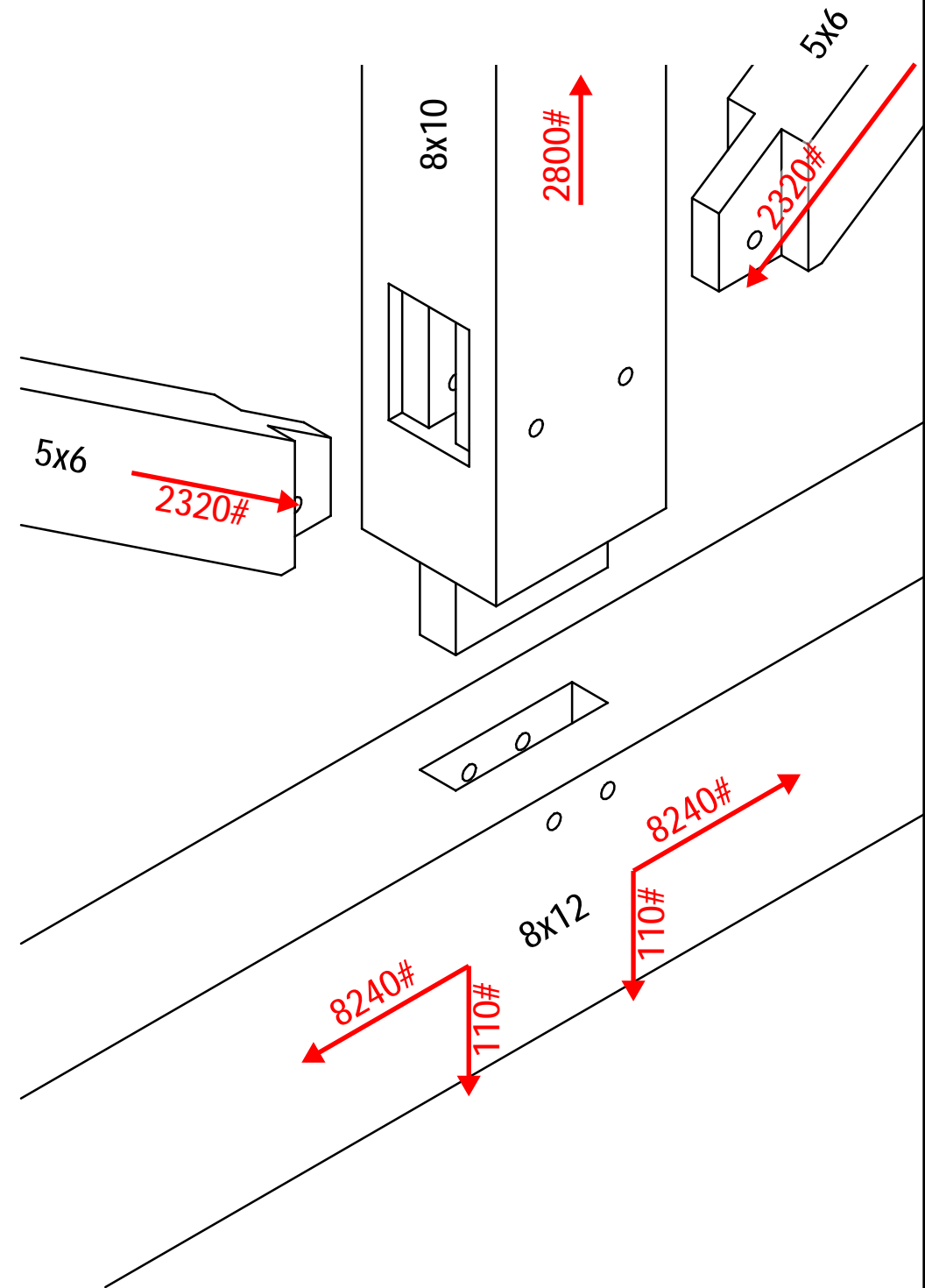

Strut / King Post Joint

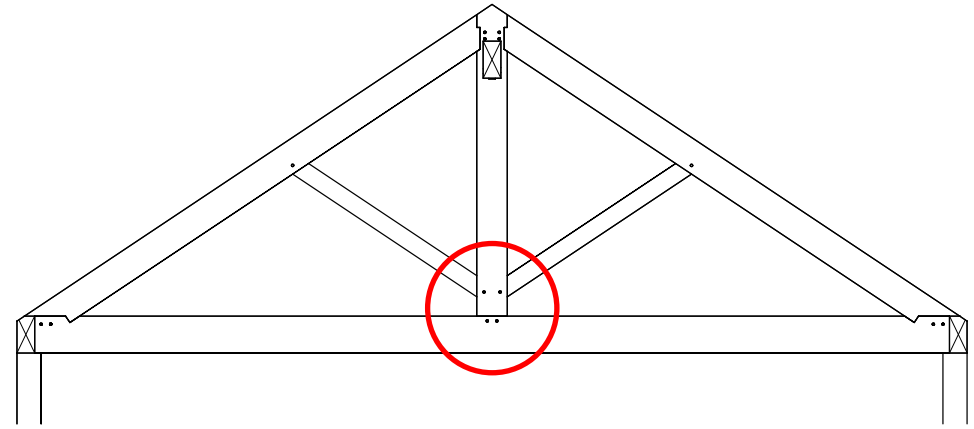
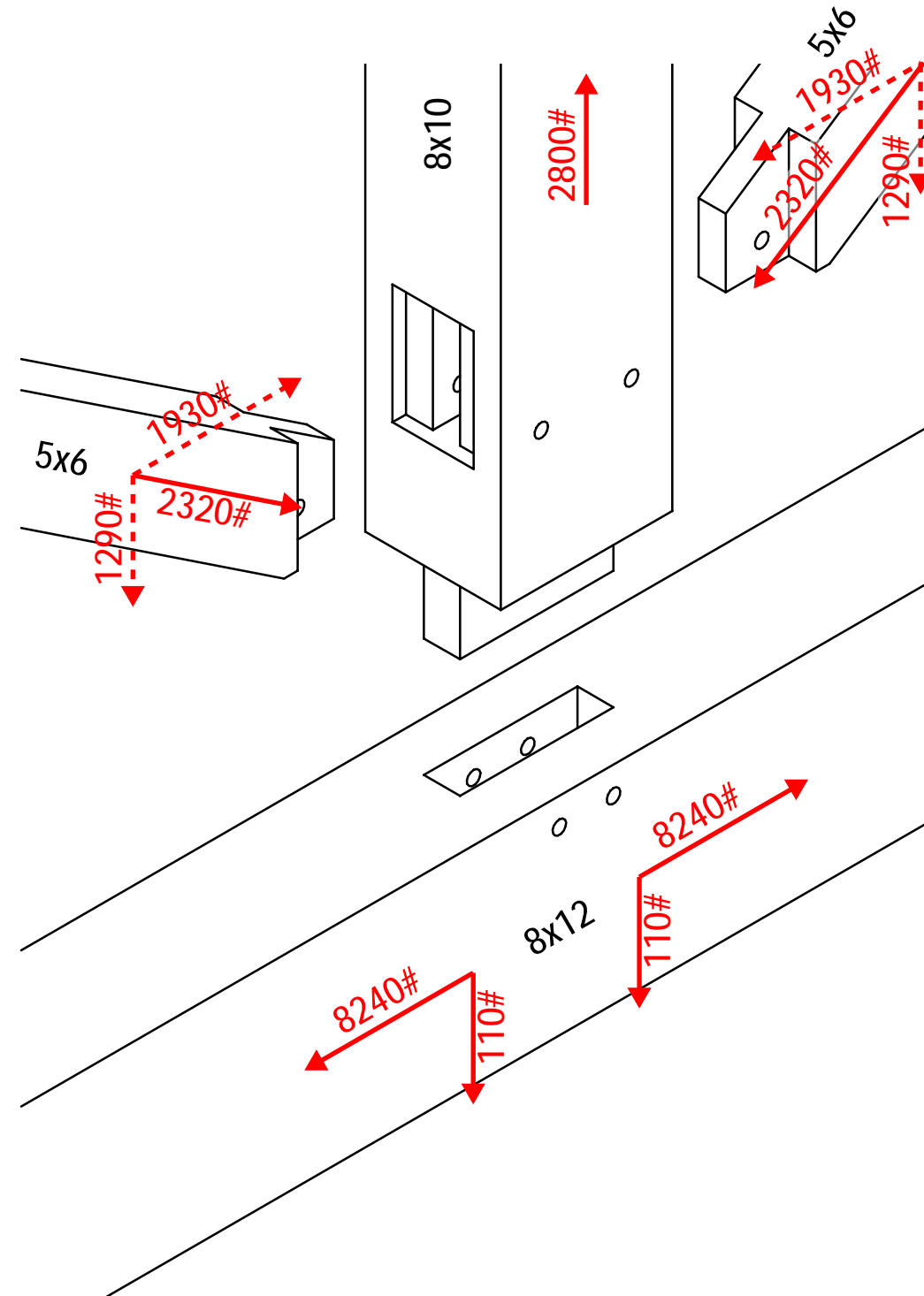

Failure Modes:

- Strut Bearing on King Post
- Shear Through King Post Relish
- King Post Tension at Reduced Section (not checked - top of king post joint will control due to lower cross-sectional area)
- Tie Tension at Reduced Section (not checked - heel joint will control)
- King Post/Tie Peg Shear (not checked- OK by inspection)

Strut / King Post Joint - Strut Bearing on King Post (Check 1)

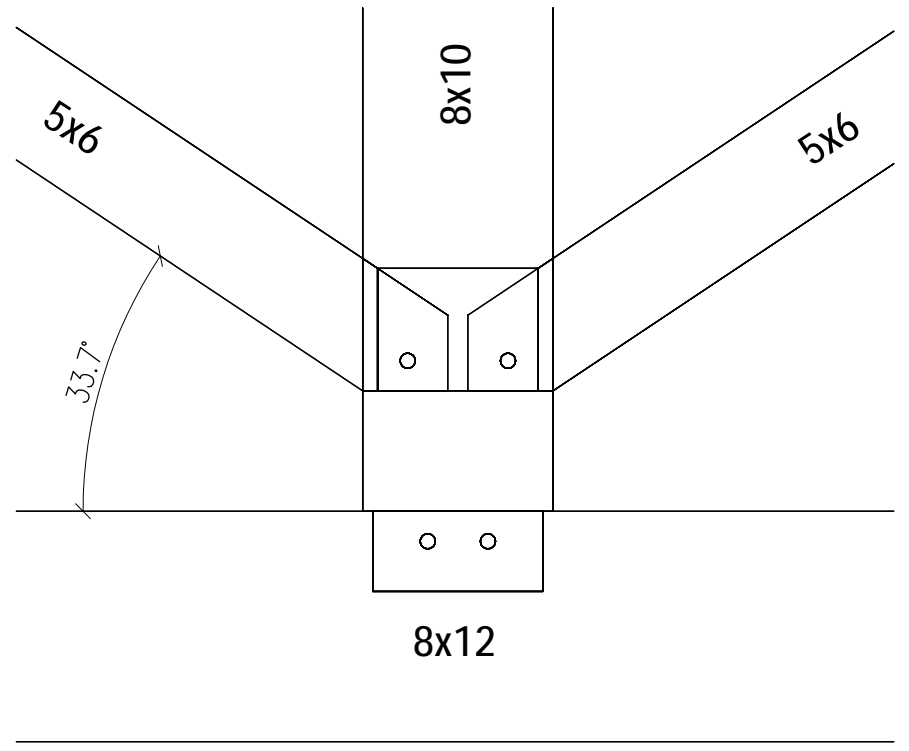
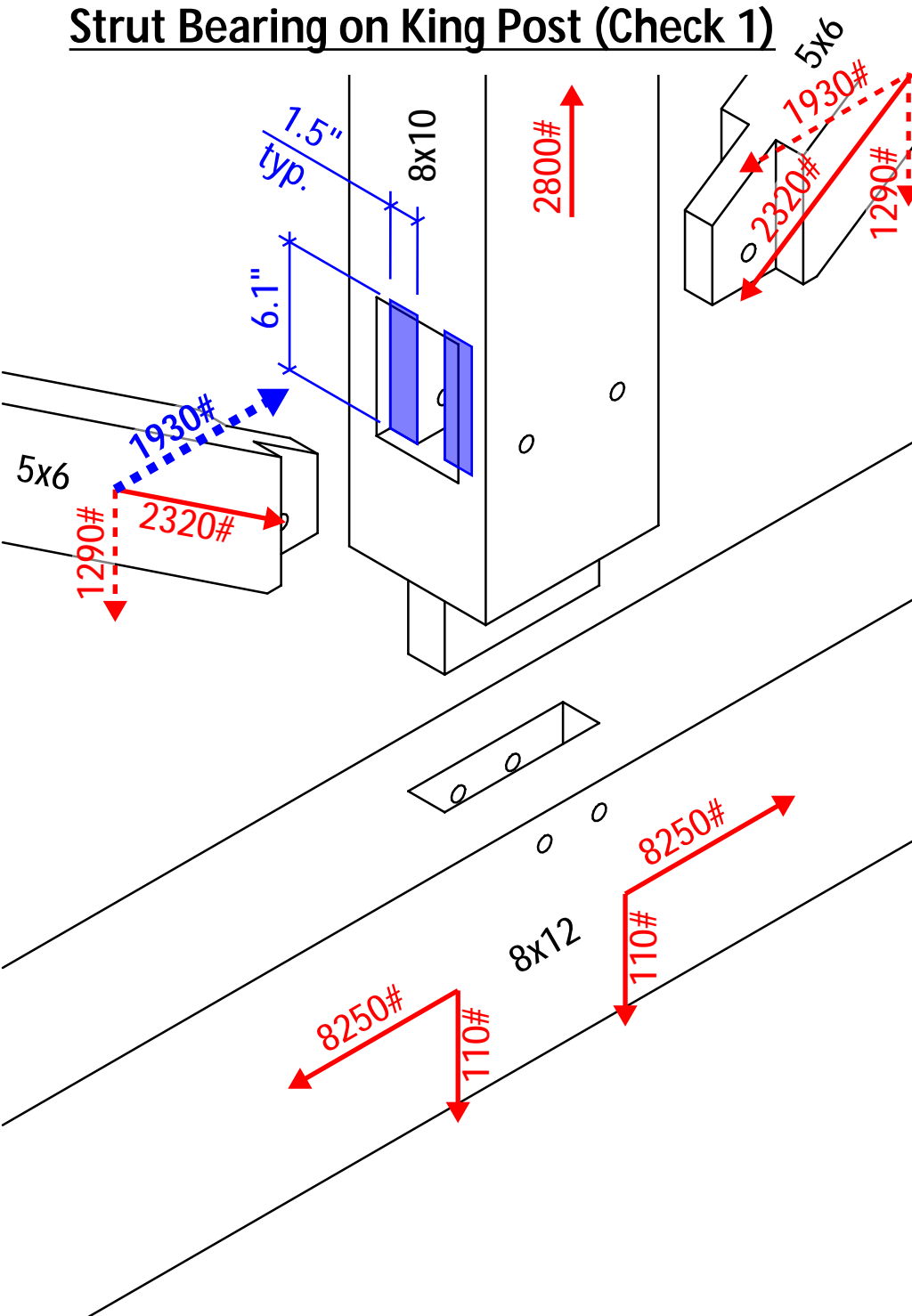

$$f_c = \frac{C}{A} = 105 \text{ psi}$$

$$C = 1,930\#$$

$$A = (1.5" * 6.1") * 2 = 18.3 \text{ in}^2$$

$$F'_c = \min. \begin{cases} F'_{33.7^\circ \text{ strut}} = 914 \text{ psi (Hankinson)} \\ F'_{c \perp \text{ king post}} = 625 \text{ psi} \end{cases}$$

$$= \boxed{625 \text{ psi} > 105 \text{ psi} \therefore \text{OK}}$$

**Strut / King Post Joint -
Strut Bearing on King Post (Check 2)**

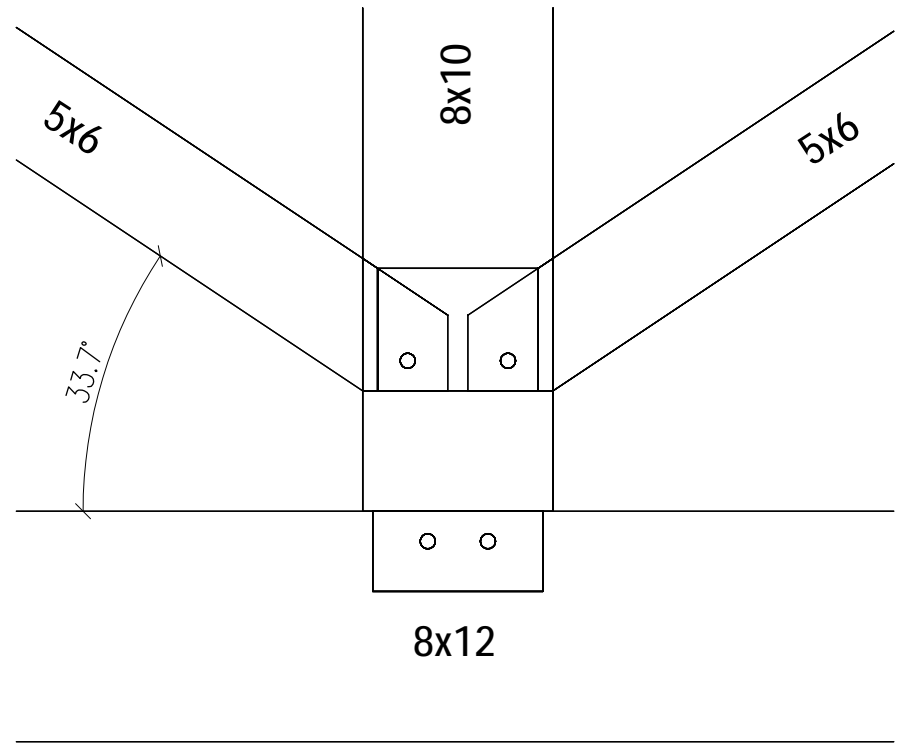
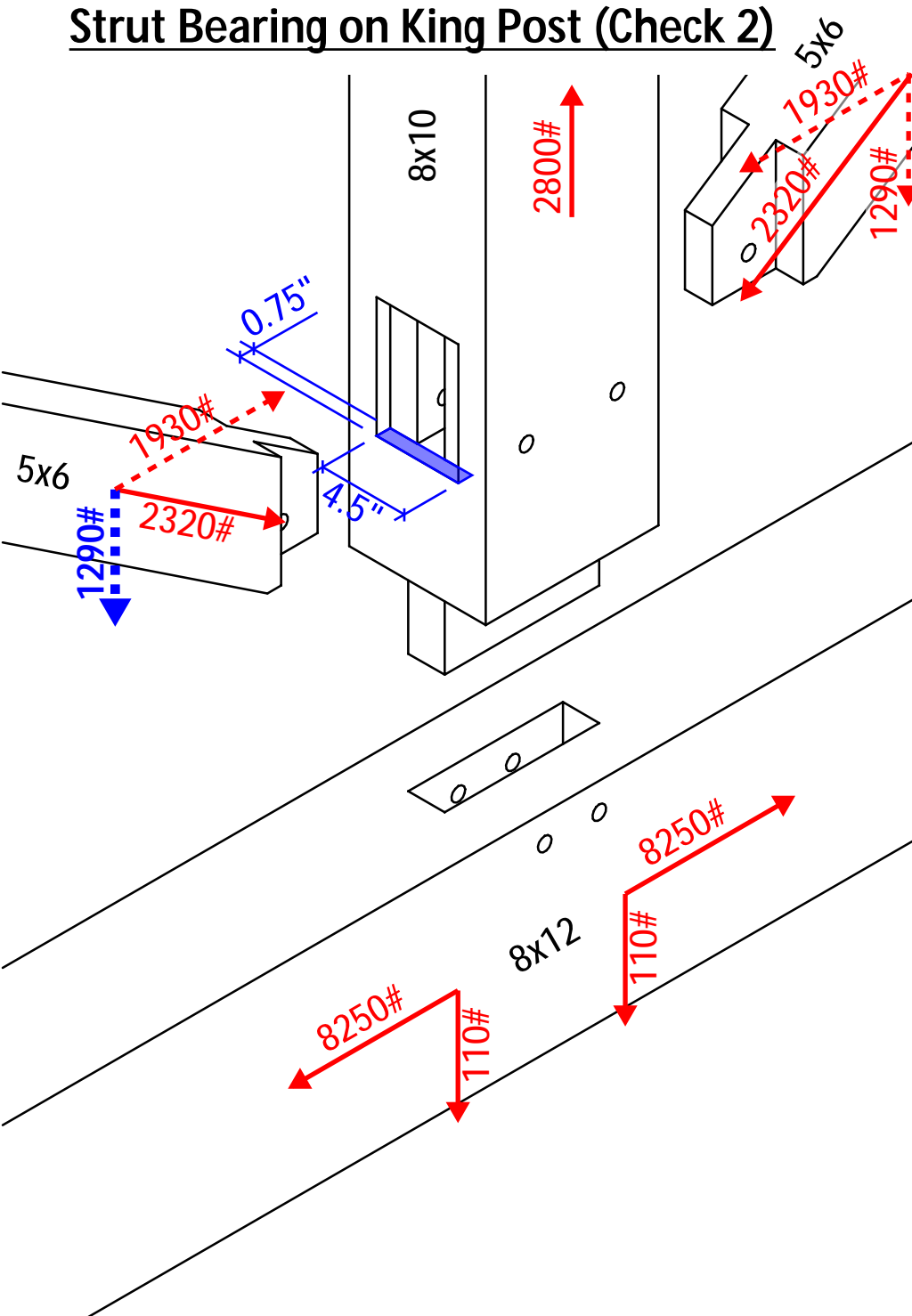

$$f_c = \frac{C}{A} = 382 \text{ psi}$$

$$C = 1,290\#$$

$$A = 0.75" * 4.5" = 3.38 \text{ in}^2$$

$$F'_c = \min. \begin{cases} F'_{56.3^\circ \text{ strut}} = 727 \text{ psi (Hankinson)} \\ F'_{c \text{ king post}} = 1,000 \text{ psi} * 1.15 = 1150 \text{ psi} \end{cases}$$

$$= \boxed{727 \text{ psi} > 382 \text{ psi} \therefore \text{OK}}$$

Strut / King Post Joint - Shear Through King Post Relish

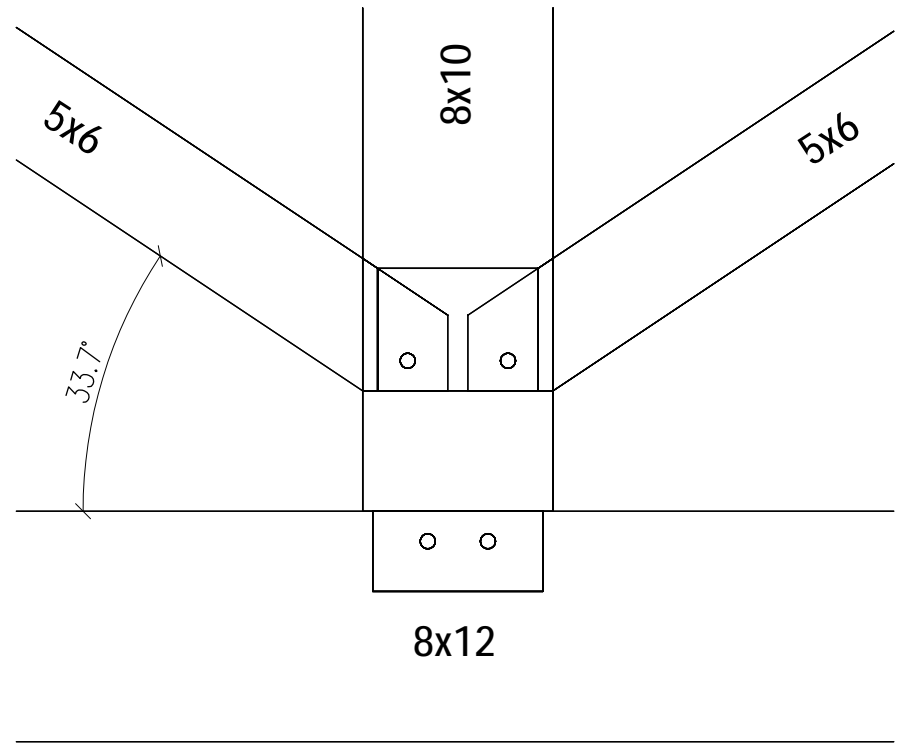
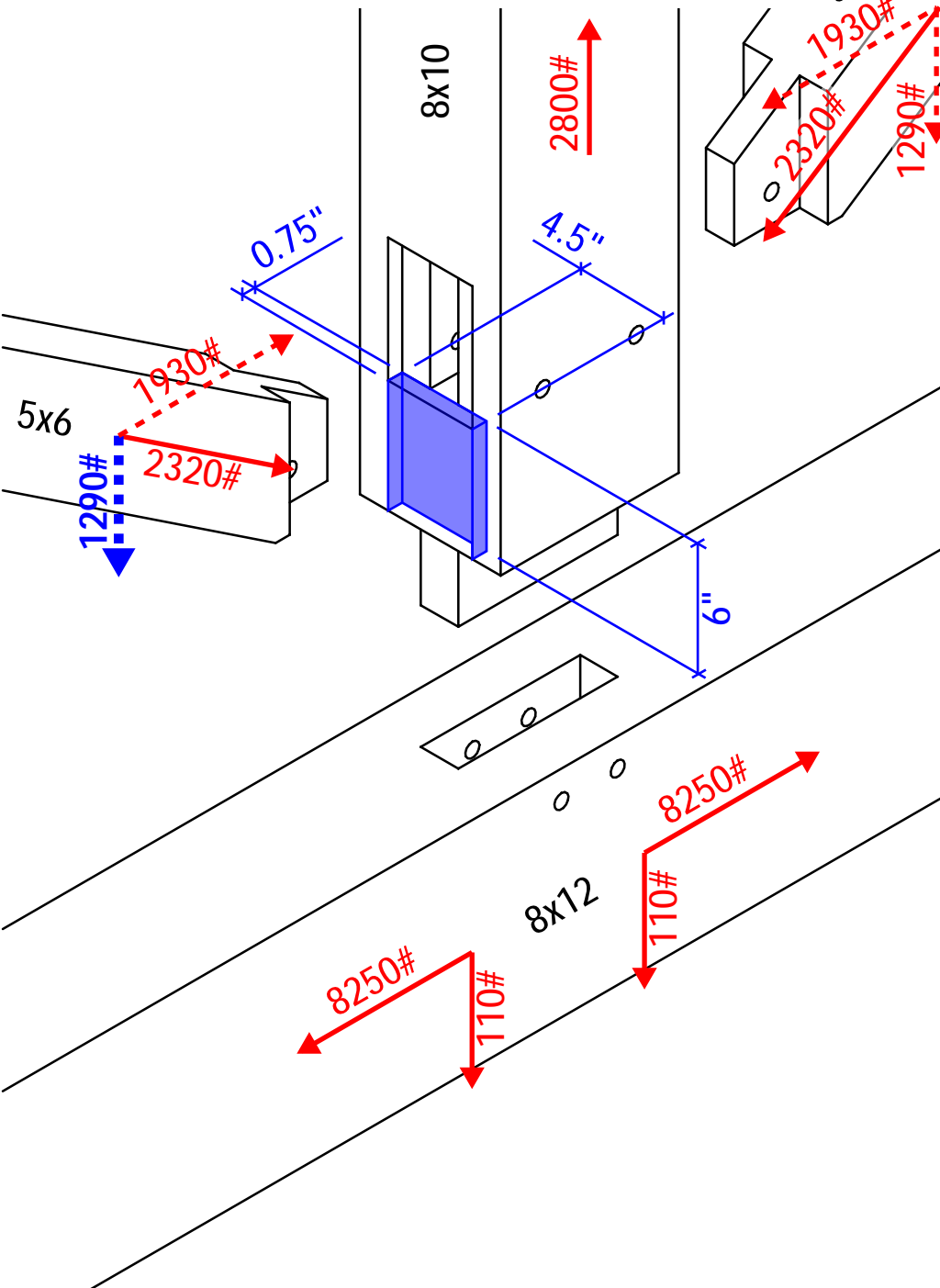

$$f_v = \frac{V}{A} = 36 \text{ psi}$$

$$V = 1,290\#$$

$$A = (0.75" * 2 + 4.5") * 6" = 36 \text{ in}^2$$

$$F'_v = 170 \text{ psi} * 1.15$$

$$= \boxed{196 \text{ psi} > 36 \text{ psi} \therefore \text{OK}}$$

Rafter / King Post Joint

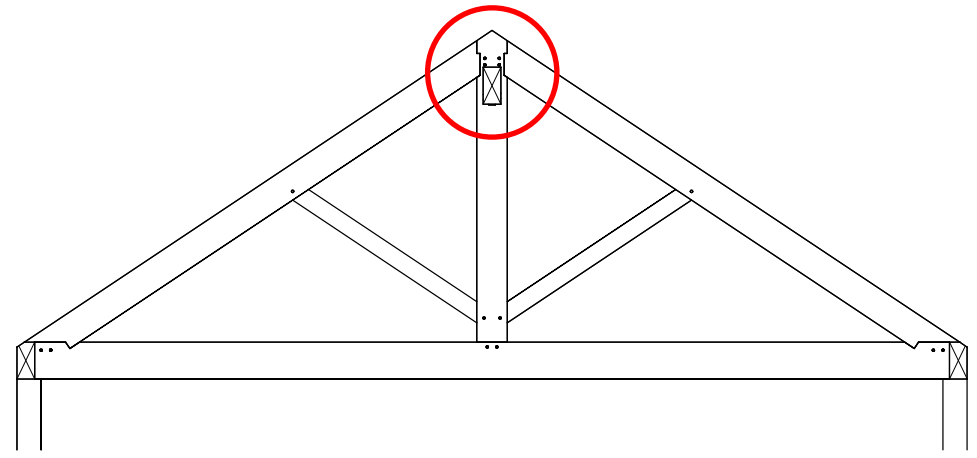
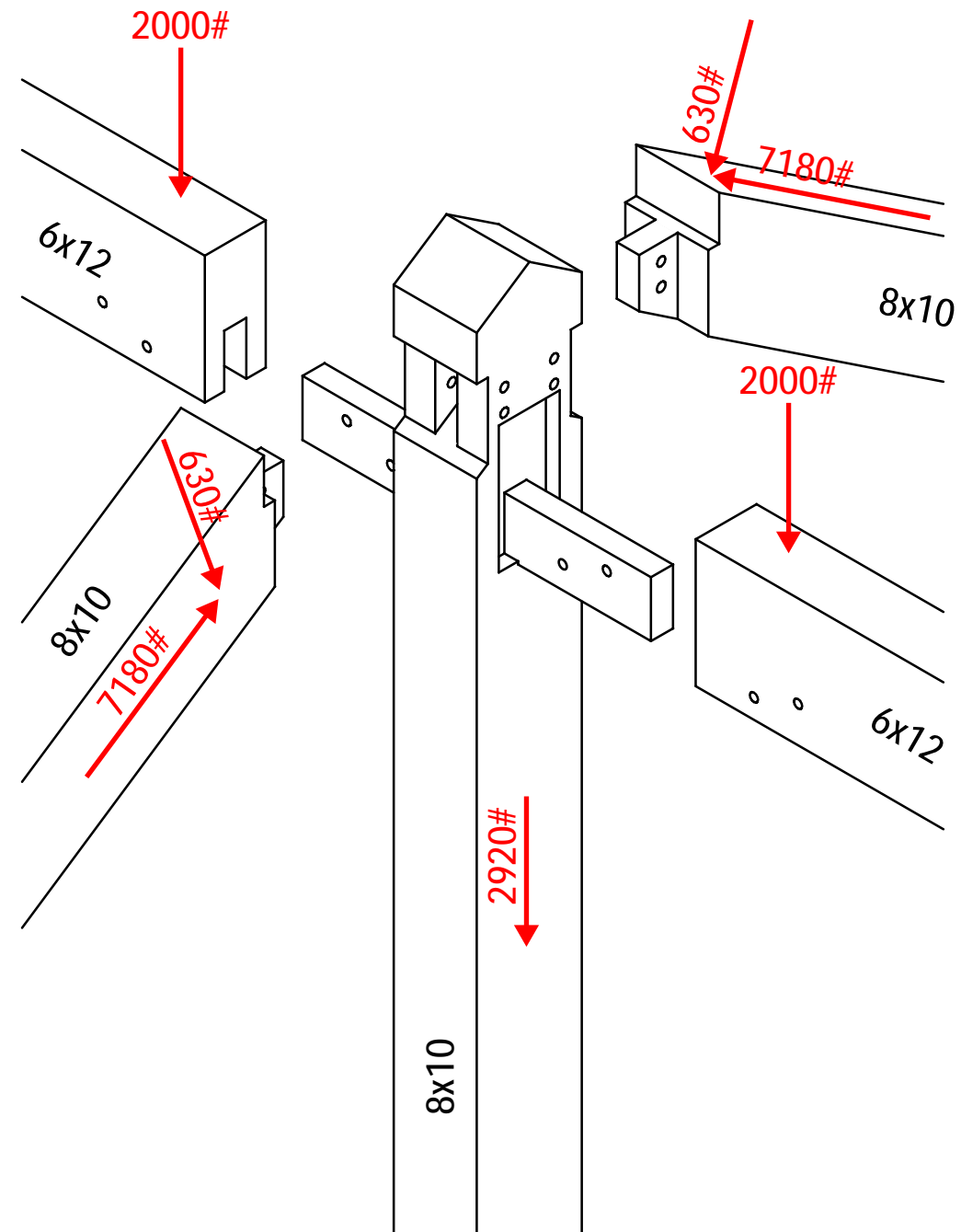

Rafter / King Post Joint

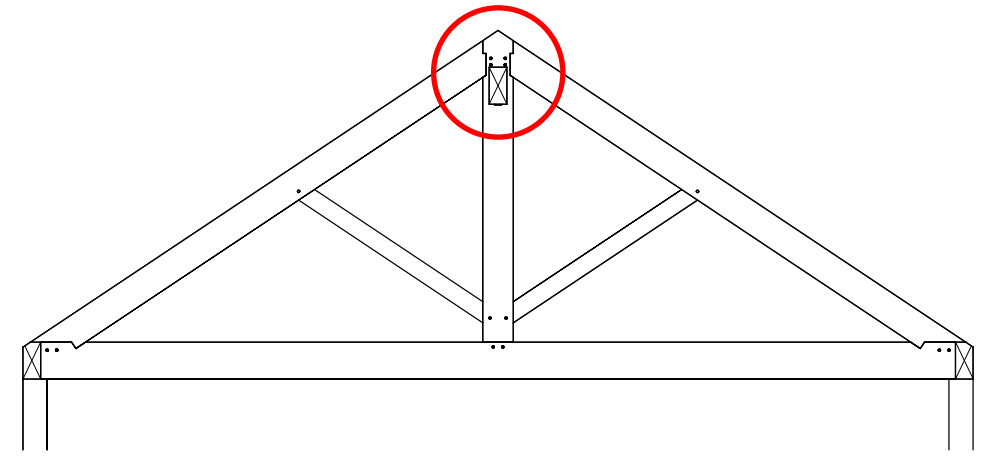
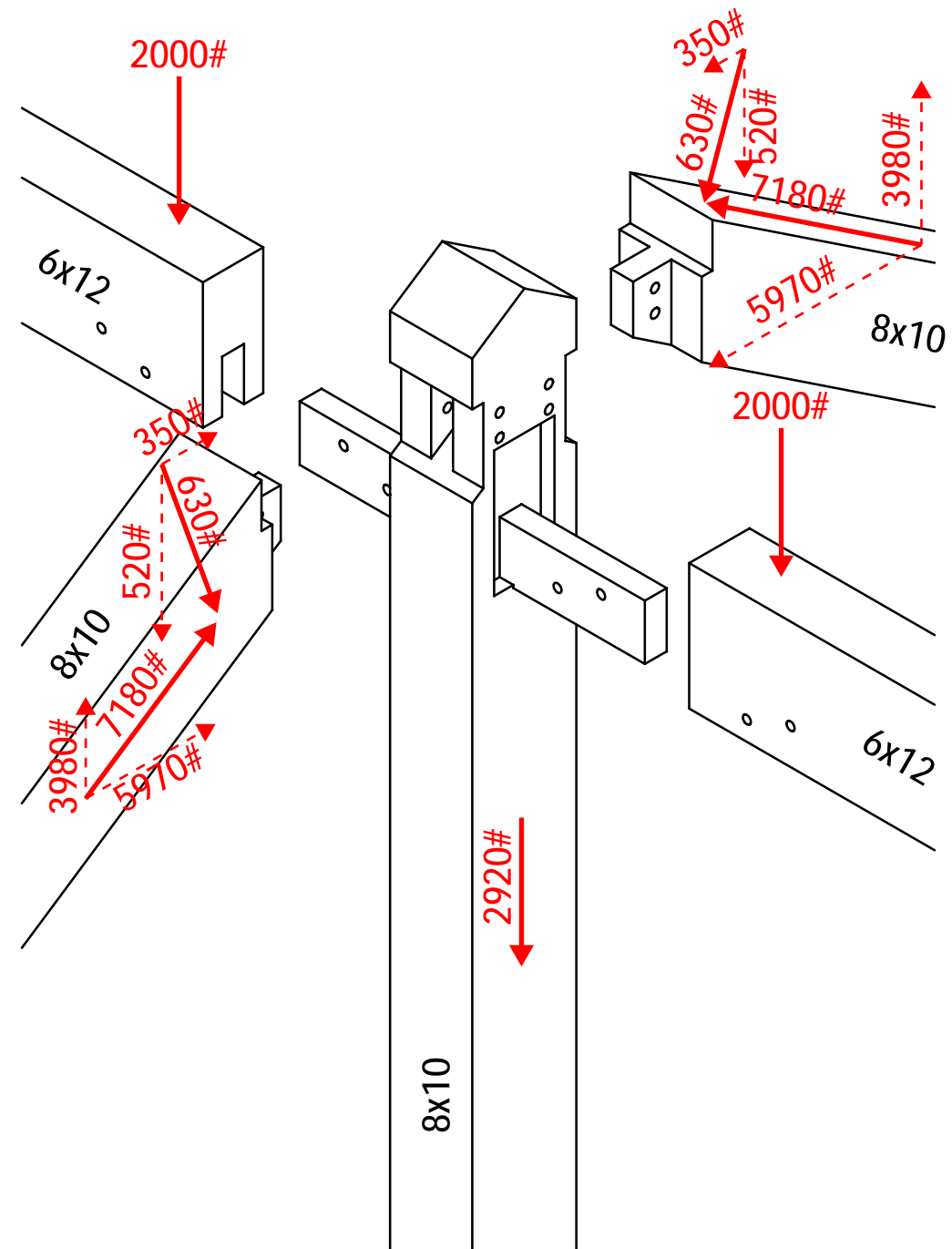

Failure Modes:

- Ridge Beam Bearing on King Post
- King Post Bearing on Rafters
- Shear Through King Post Relish
- King Post Tension at Reduced Section
- Rafter Compression over Effective Area at Connection

Rafter / King Post Joint - Ridge Beam Bearing on King Post

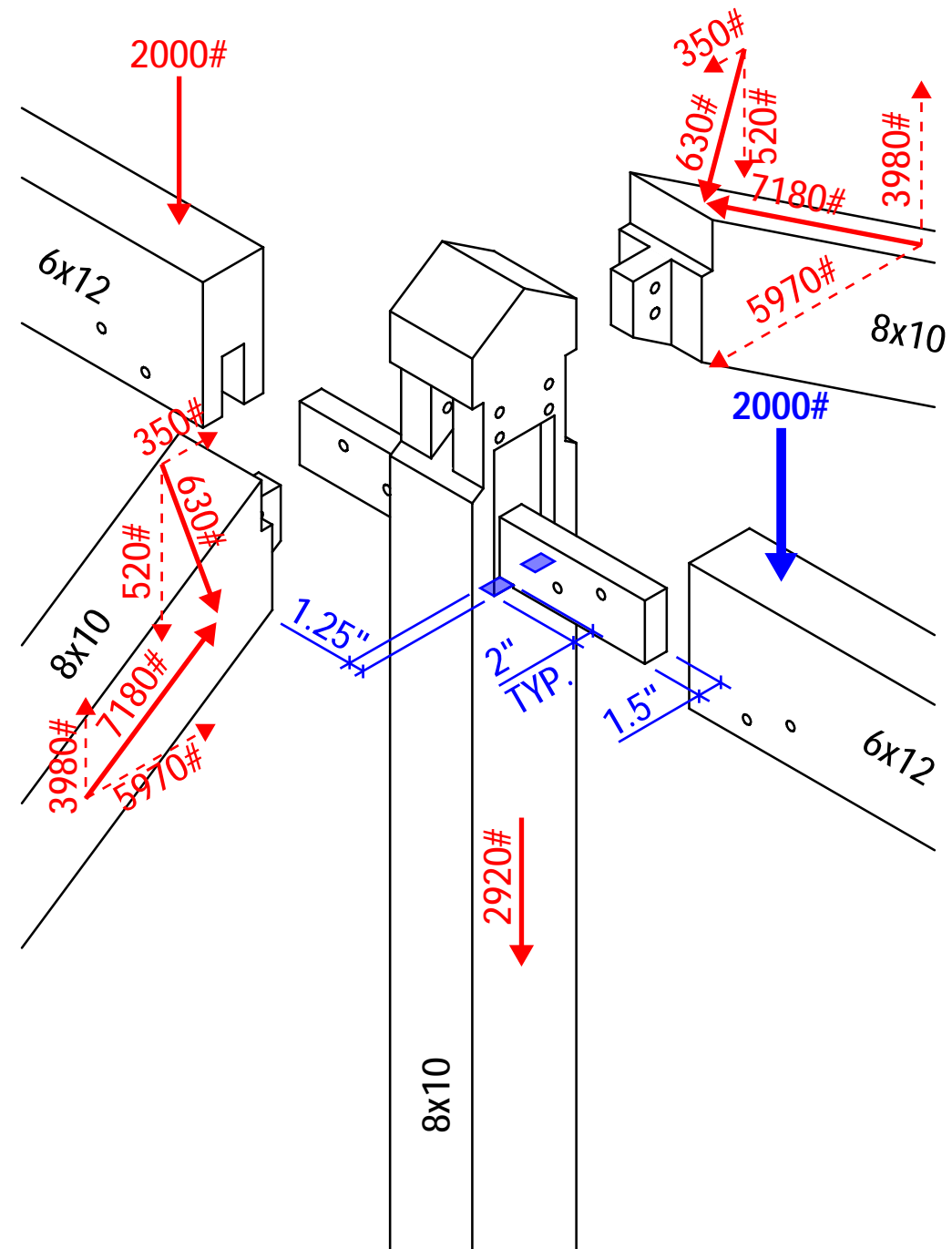

$$f_c = \frac{C}{A} = 500 \text{ psi}$$

$$C = 2,000\#$$

$$A = (1.25" - 0.25" \text{ shrinkage}) \times (5.5" - 1.5") = 4.00 \text{ in}^2$$

$$F'_c$$

$$= \min. \begin{cases} F'_{c \perp \text{ ridge}} = 625 \text{ psi} \\ F'_{c \text{ king post}} = 1,000 \text{ psi} * 1.15 = 1,150 \text{ psi} \end{cases}$$

$$= \boxed{625 \text{ psi} > 500 \text{ psi} \therefore \text{OK}}$$

Rafter / King Post Joint - King Post Bearing on Rafters (Check 1)

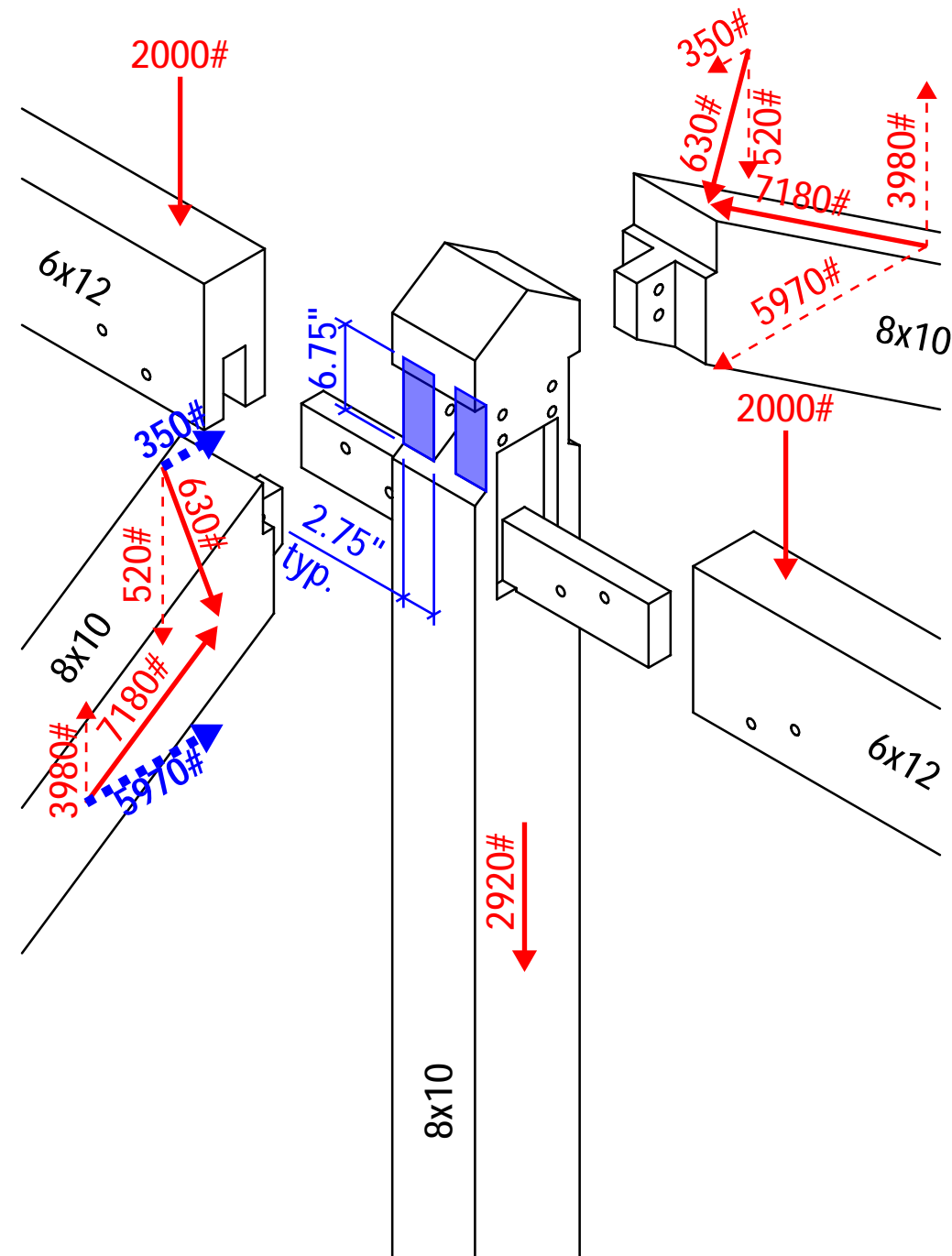

$$f_c = \frac{C}{A} = 170 \text{ psi}$$

$$C = 5,970\# + 350\# = 6,320\#$$

$$A = (6.75" * 2.75") * 2 = 37.1 \text{ in}^2$$

F'_c

$$= \min. \begin{cases} F'_{c \perp \text{ king post}} = 625 \text{ psi} \\ F'_{33.7^\circ \text{ rafter}} = 914 \text{ psi (Hankinson)} \end{cases}$$

$$= \boxed{625 \text{ psi} > 170 \text{ psi} \therefore \text{OK}}$$

Rafter / King Post Joint - King Post Bearing on Rafters (Check 2)

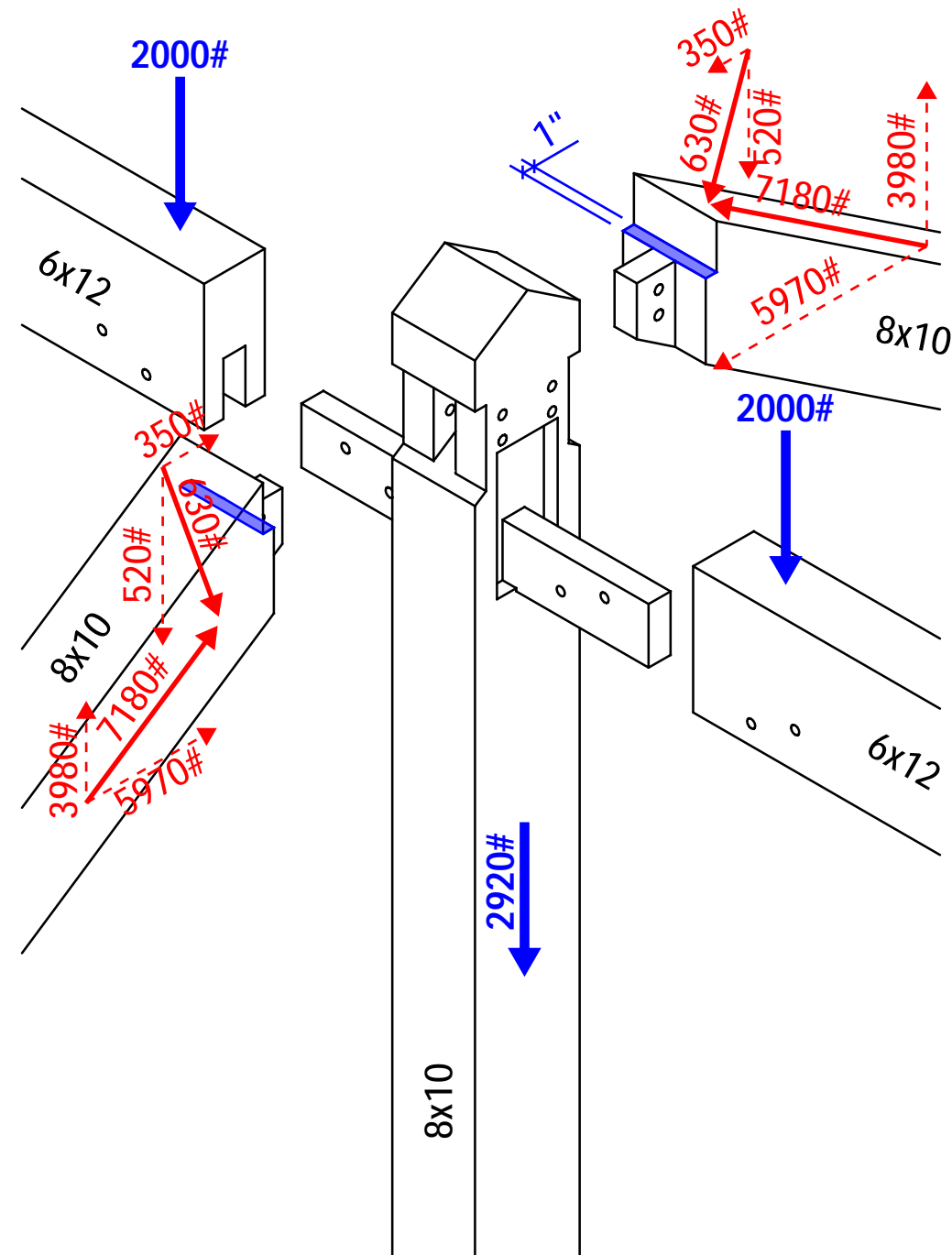

$$f_c = \frac{C}{A} = 461 \text{ psi}$$

$$C = 2,920\# + 2,000\# + 2,000\# = 6,920\#$$

$$A = (1" * 7.5")^2 = 15 \text{ in}^2$$

F'_c

$$= \min. \begin{cases} F'_c \text{ king post} = 1,000 \text{ psi} * 1.15 = 1,150 \text{ psi} \\ F'_{56.3^\circ \text{ rafter}} = 727 \text{ psi (Hankinson)} \end{cases}$$

$$= \boxed{727 \text{ psi} > 461 \text{ psi} \therefore \text{OK}}$$

Rafter / King Post Joint - Shear Through King Post Relish

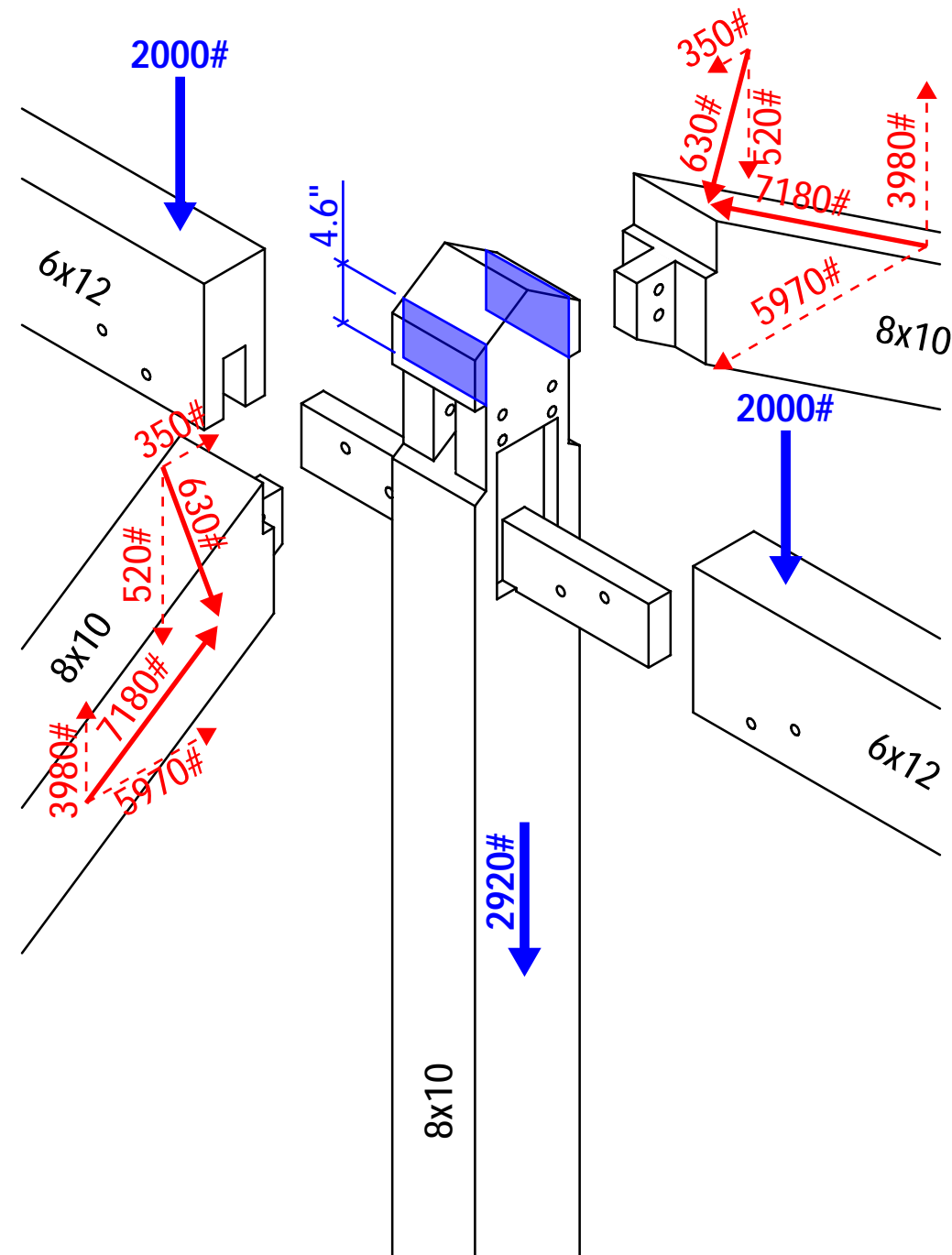

Conservatively neglecting rafter tenons

$$f_v = \frac{V}{A} = 100 \text{ psi}$$

$$V = 2,920\# + 2,000\# + 2,000\# = 6,920\#$$

$$A = (4.6" * 7.5") * 2 = 69.0 \text{ in}^2$$

$$F'_v = 170 \text{ psi} * 1.15$$

$$= \boxed{196 \text{ psi} > 100 \text{ psi} \therefore \text{OK}}$$

Rafter / King Post Joint - King Post Tension at Reduced Section

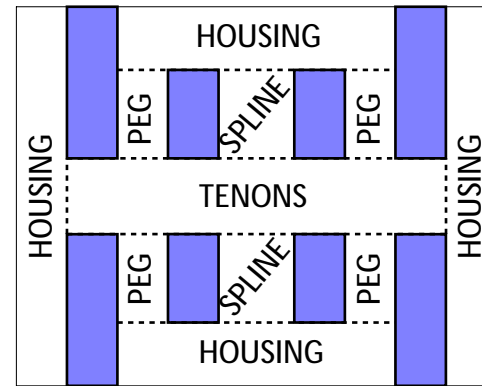
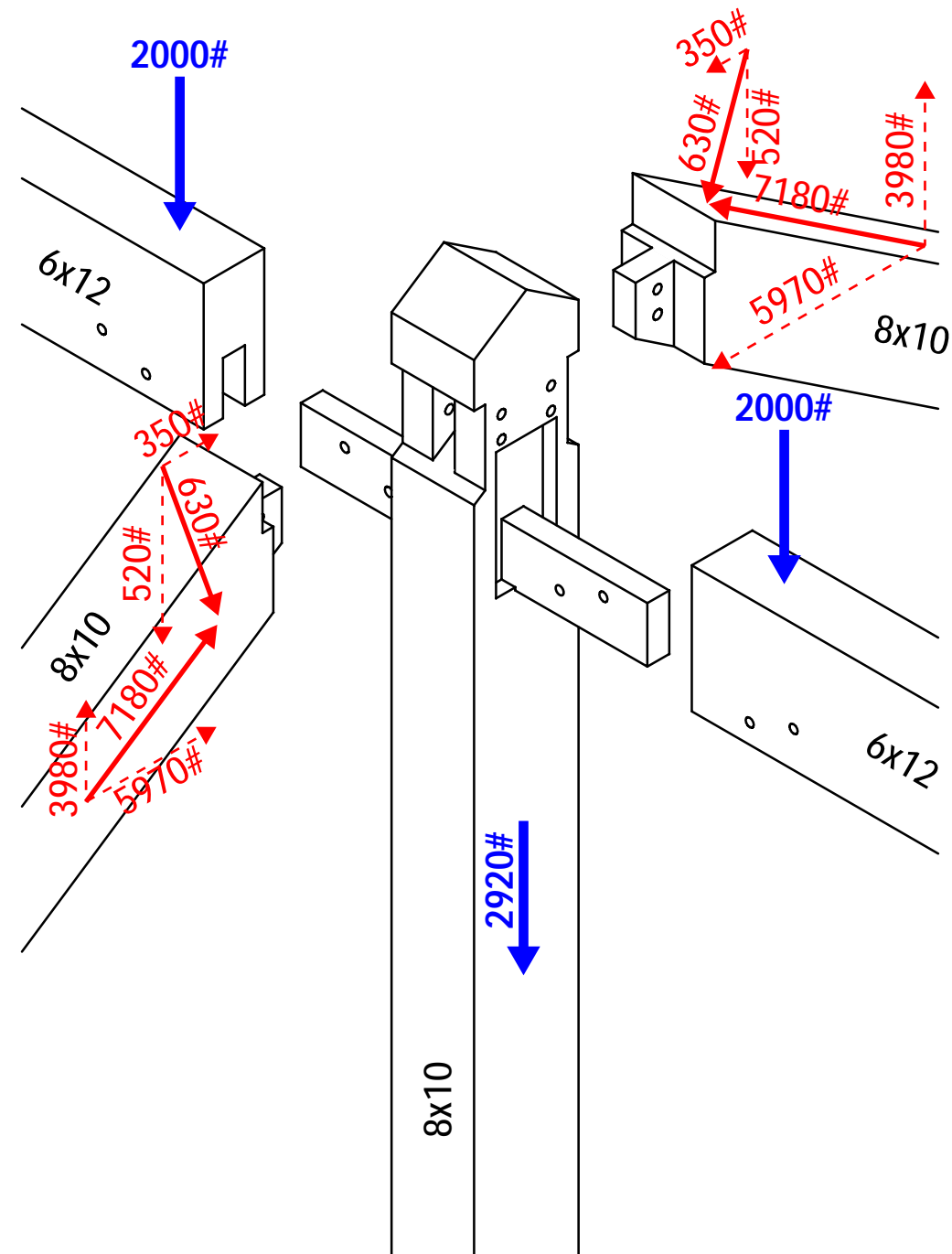

$$A = 19.0 \text{ in}^2$$

King Post Cross Section

$$f_t = \frac{T}{A} = 364 \text{ psi}$$

$$T = 2,920\# + 2,000\# + 2,000\# = 6,920\#$$

$$A = 19.0 \text{ in}^2$$

$$F'_t = 825 \text{ psi} * 1.15$$

$$= \boxed{949 \text{ psi} > 364 \text{ psi} \therefore \text{OK}}$$

Rafter / King Post Joint -
Rafter Compression Over Effective
Area at Connection

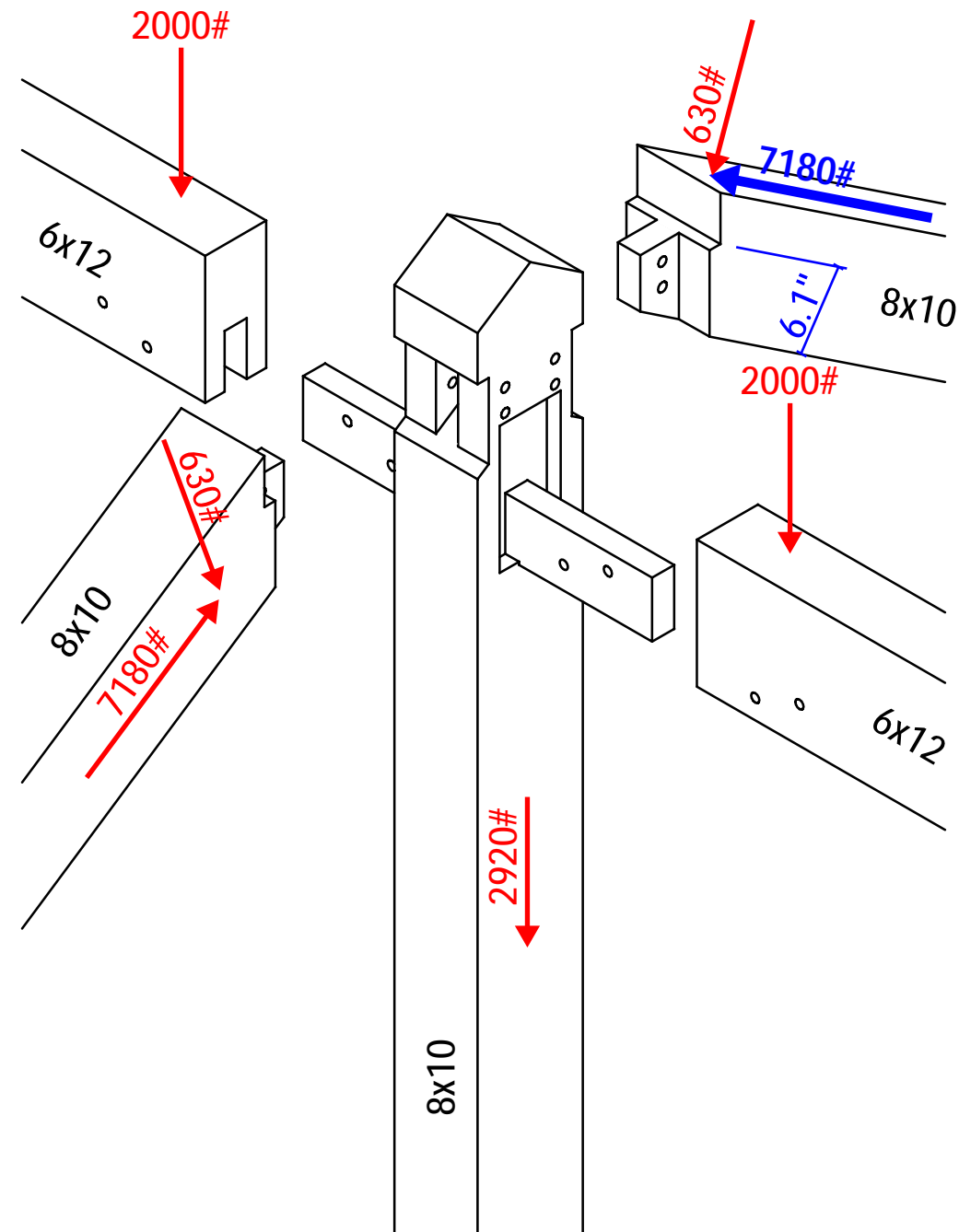

$$f_c = \frac{C}{A} = 157 \text{ psi}$$

$$C = 7,180\#$$

$$A = 6.1" * 7.5" = 45.8 \text{ in}^2$$

$$F'_c = 1,000 \text{ psi} * 1.15$$

$$= \boxed{1,150 \text{ psi} > 157 \text{ psi} \therefore \text{OK}}$$

Heel Joint

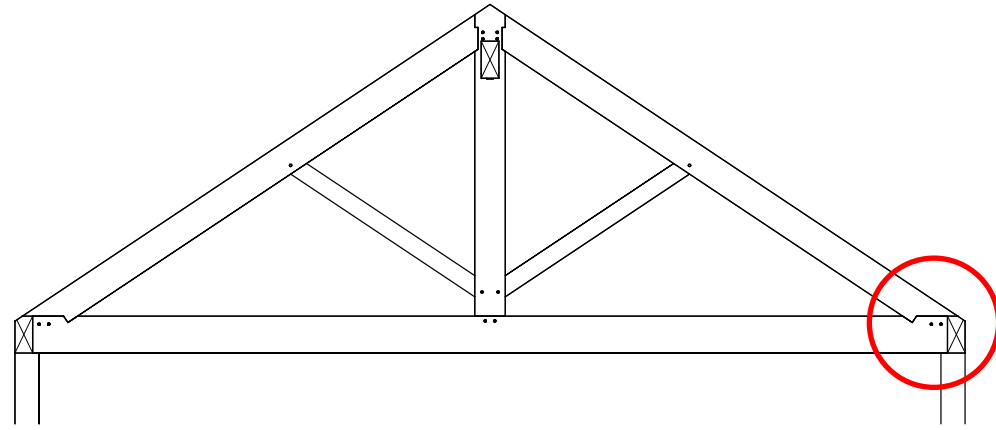
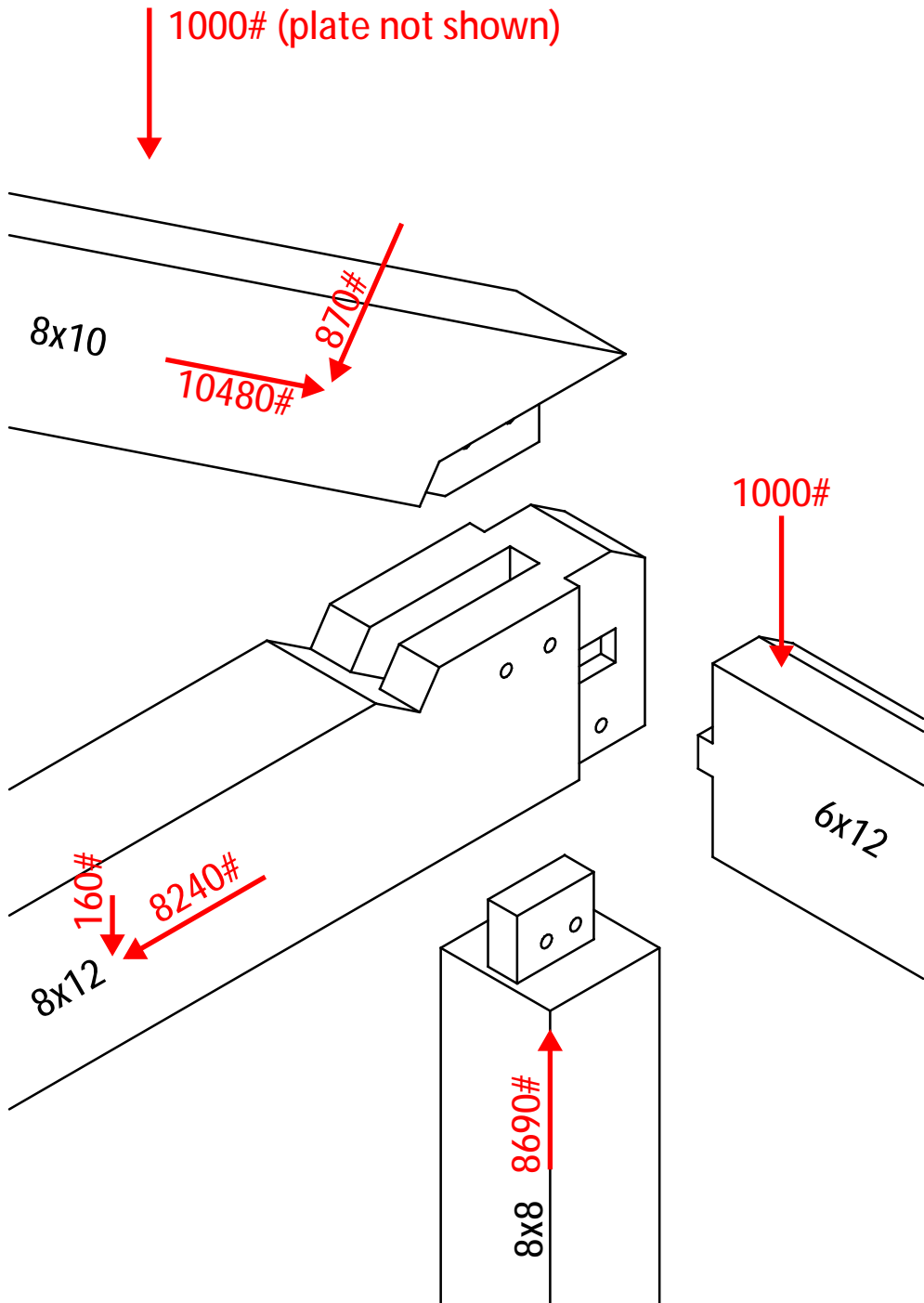

Heel Joint

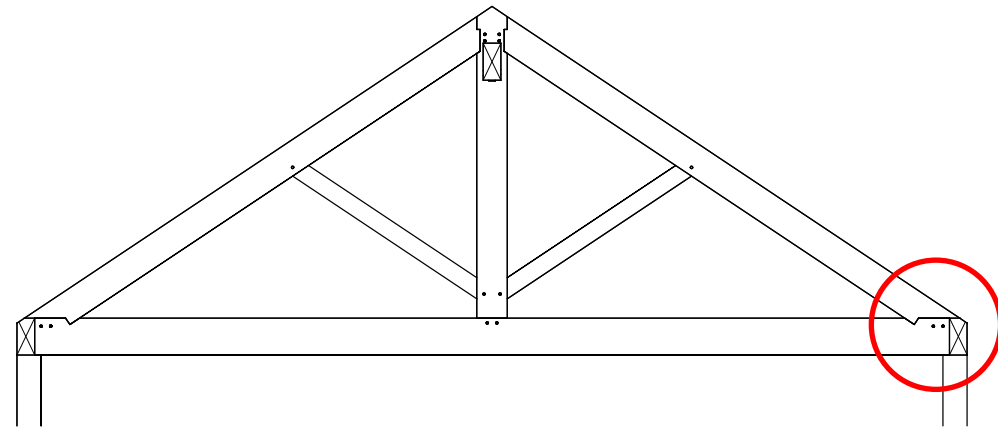
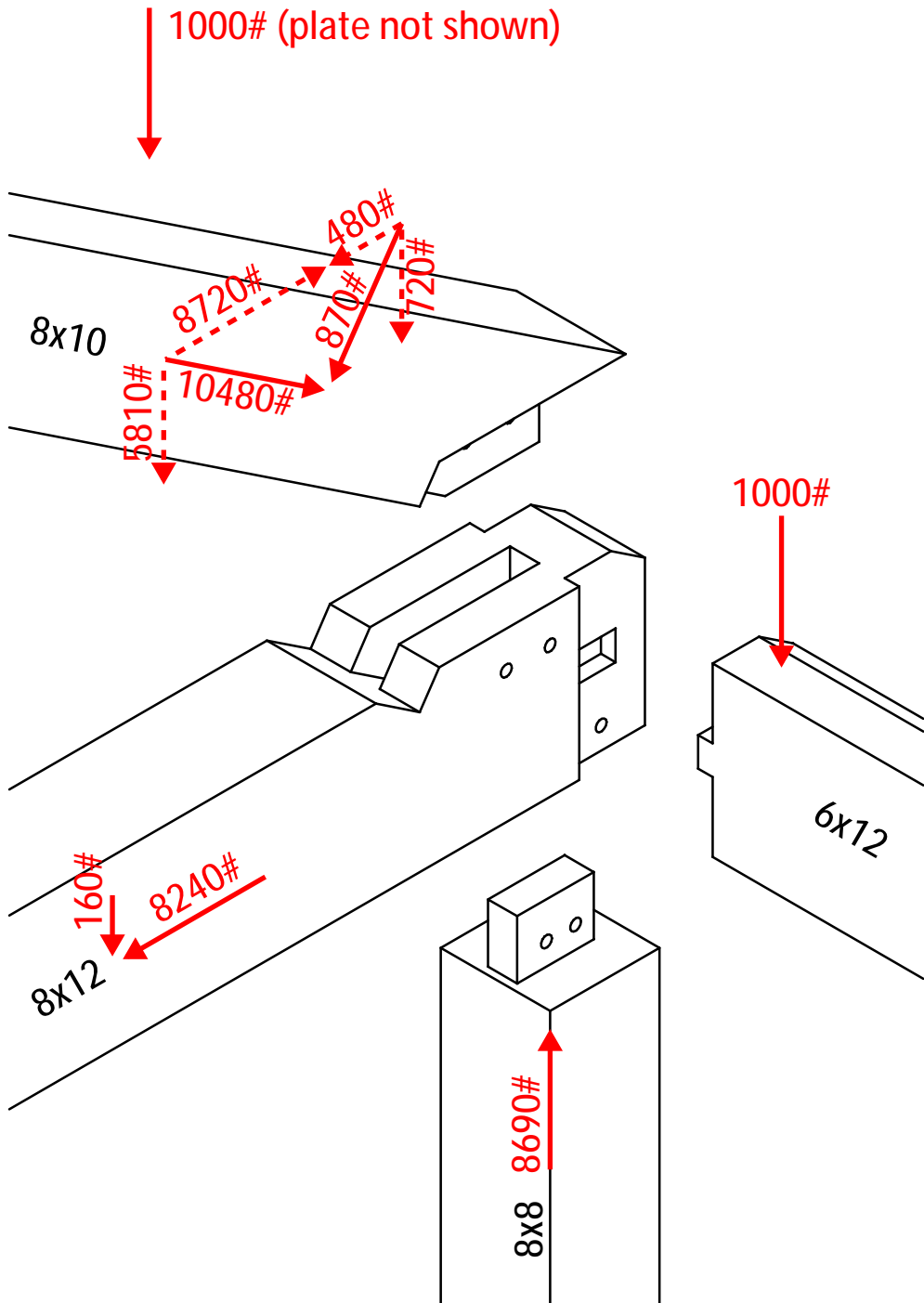

Failure Modes:

- Plate Bearing on Post
- Rafter Bearing on Tie
- Shear Through Tie Relish
- Tie Tension at Reduced Section
- Tie Bearing on Post

Heel Joint - Plate Bearing on Post

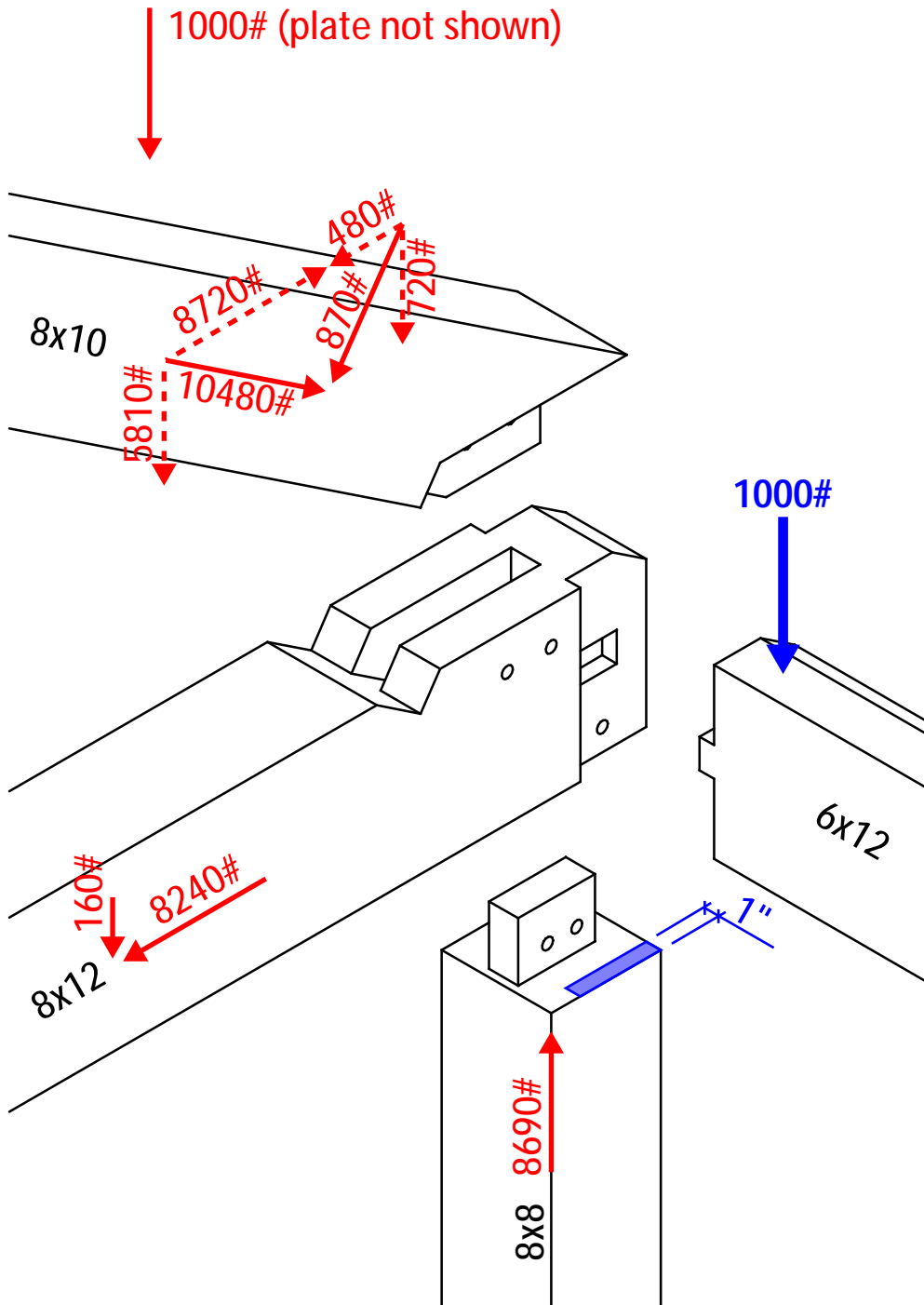

$$f_c = \frac{C}{A} = 242 \text{ psi}$$

$$C = 1,000\#$$

$$A = (1" - 0.25" \text{ shrinkage}) * (5.5") \\ = 4.13 \text{ in}^2$$

$$F'_c$$

$$= \min. \begin{cases} F'_{c \perp \text{plate}} = 625 \text{ psi} \\ F'_{c \text{ post}} = 1,000 \text{ psi} * 1.15 = 1,150 \text{ psi} \end{cases}$$

$$= \boxed{625 \text{ psi} > 242 \text{ psi} \therefore \text{OK}}$$

Heel Joint - Rafter Bearing on Tie

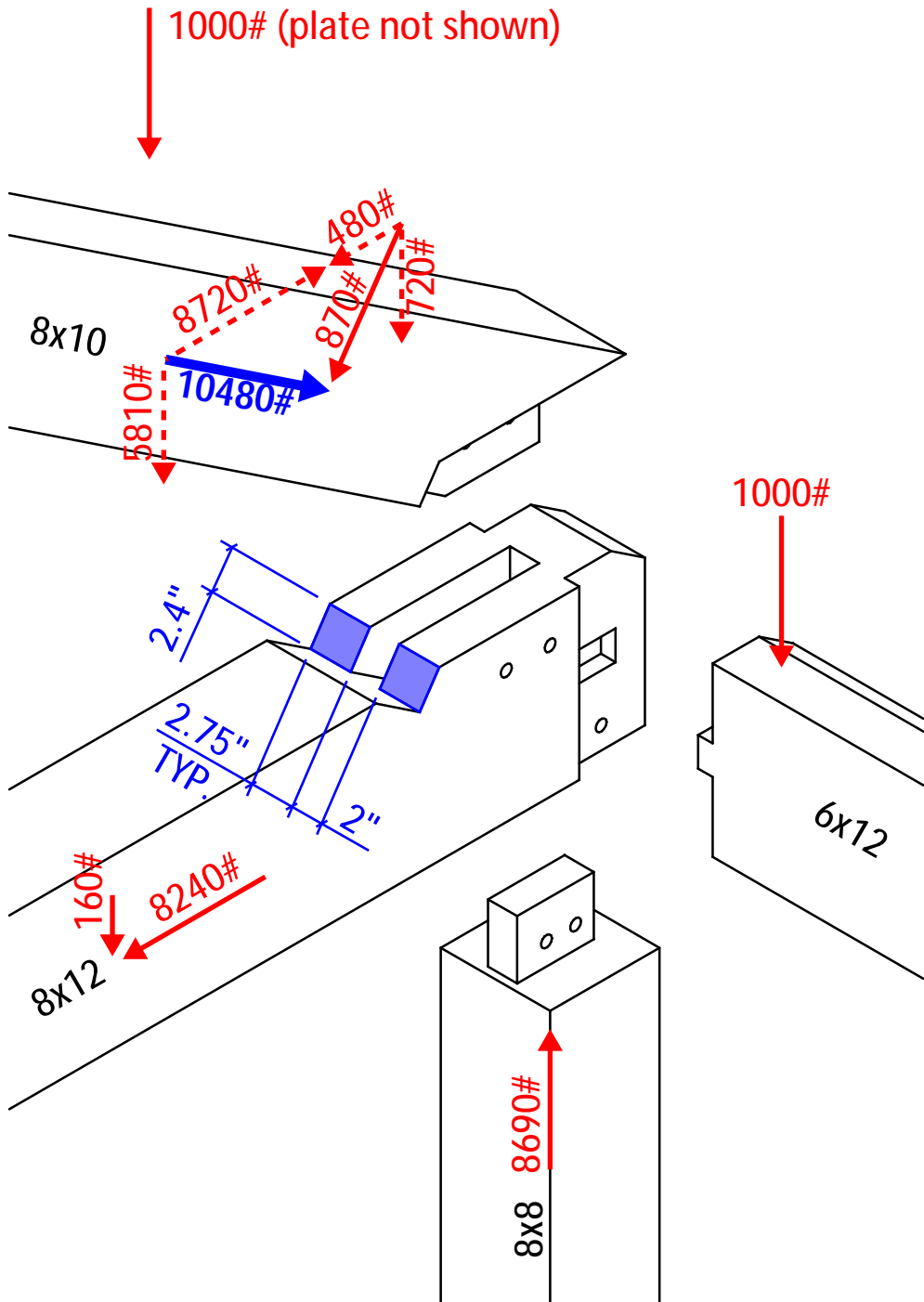

$$f_c = \frac{C}{A} = 793 \text{ psi}$$

$$C = 10,480\#$$

$$A = (2.4" * 2.75") * 2 = 13.2 \text{ in}^2$$

F'_c

$$= \min. \begin{cases} F'_{33.7^\circ \text{ tie}} = 875 \text{ psi (hankinson)} \\ F'_{\text{rafter}} = 1,000 \text{ psi} * 1.15 = 1,150 \text{ psi} \end{cases}$$

$$= \boxed{875 \text{ psi} > 793 \text{ psi} \therefore \text{OK}}$$

Heel Joint -
Shear Through Tie Relish

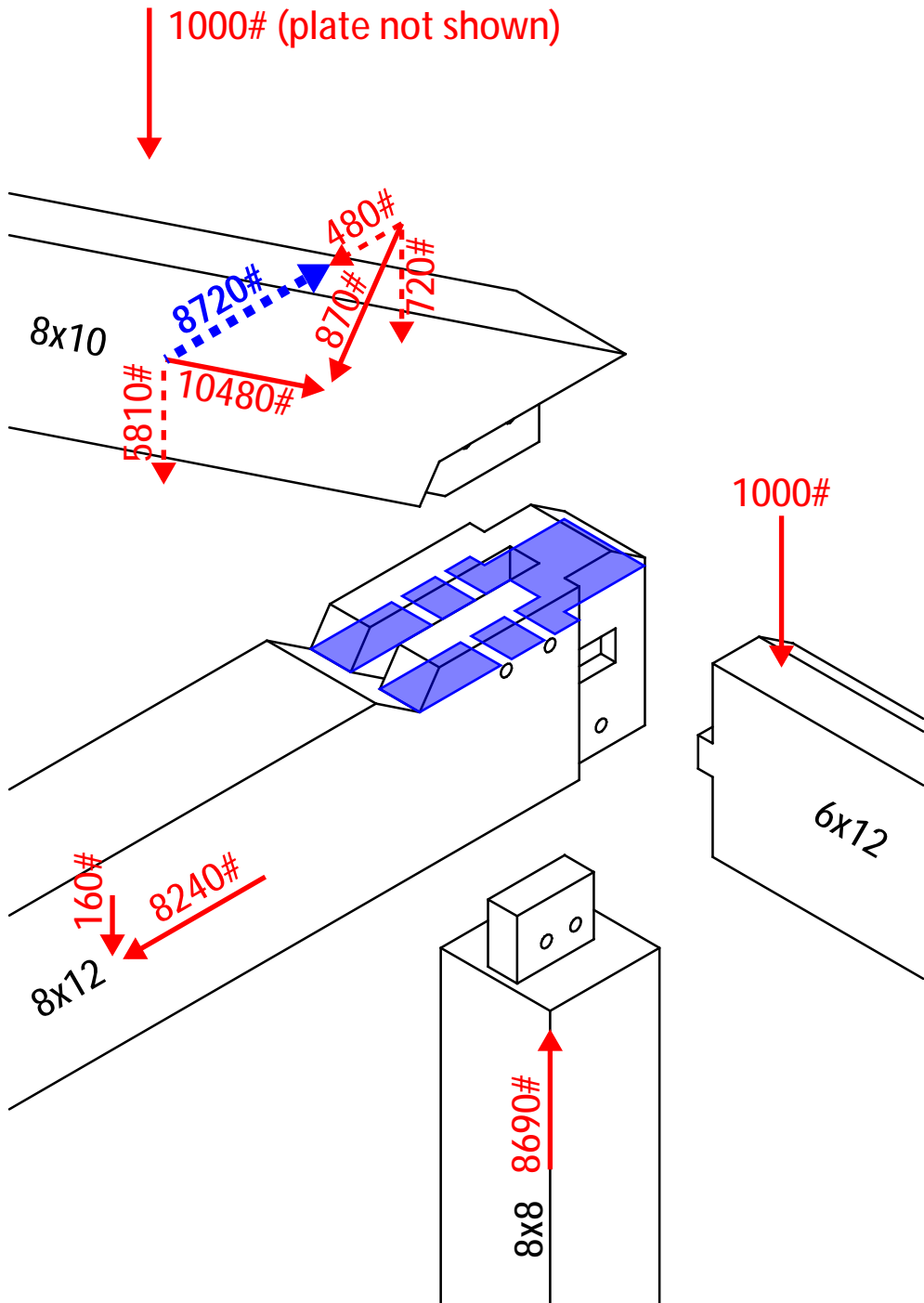

$$f_v = \frac{V}{A} = 109 \text{ psi}$$

$$V = 8,720\#$$

$$A = 79.8 \text{ in}^2$$

$$F'_v = 170 \text{ psi} * 1.15$$

$$= \boxed{196 \text{ psi} > 109 \text{ psi} \therefore \text{OK}}$$

Heel Joint - Tie Tension at Reduced Section

1000# (plate not shown)

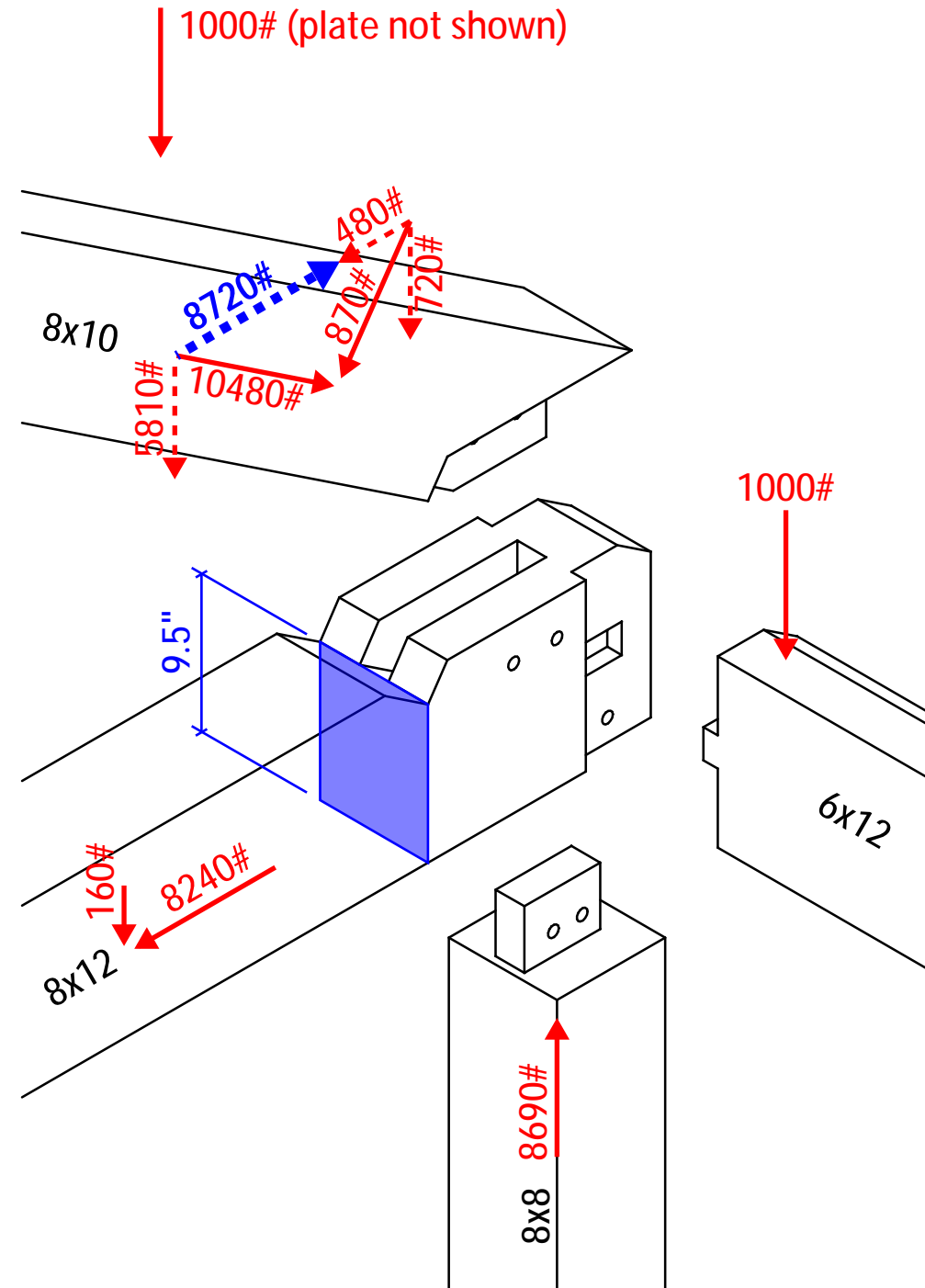

$$f_t = \frac{T}{A} = 122 \text{ psi}$$

$$T = 8,720\#$$

$$A = 9.5" * 7.5" = 71.3 \text{ in}^2$$

$$F'_t = 675 \text{ psi} * 1.15$$

$$= \boxed{776 \text{ psi} > 122 \text{ psi} \therefore \text{OK}}$$

Heel Joint - Tie Bearing on Post

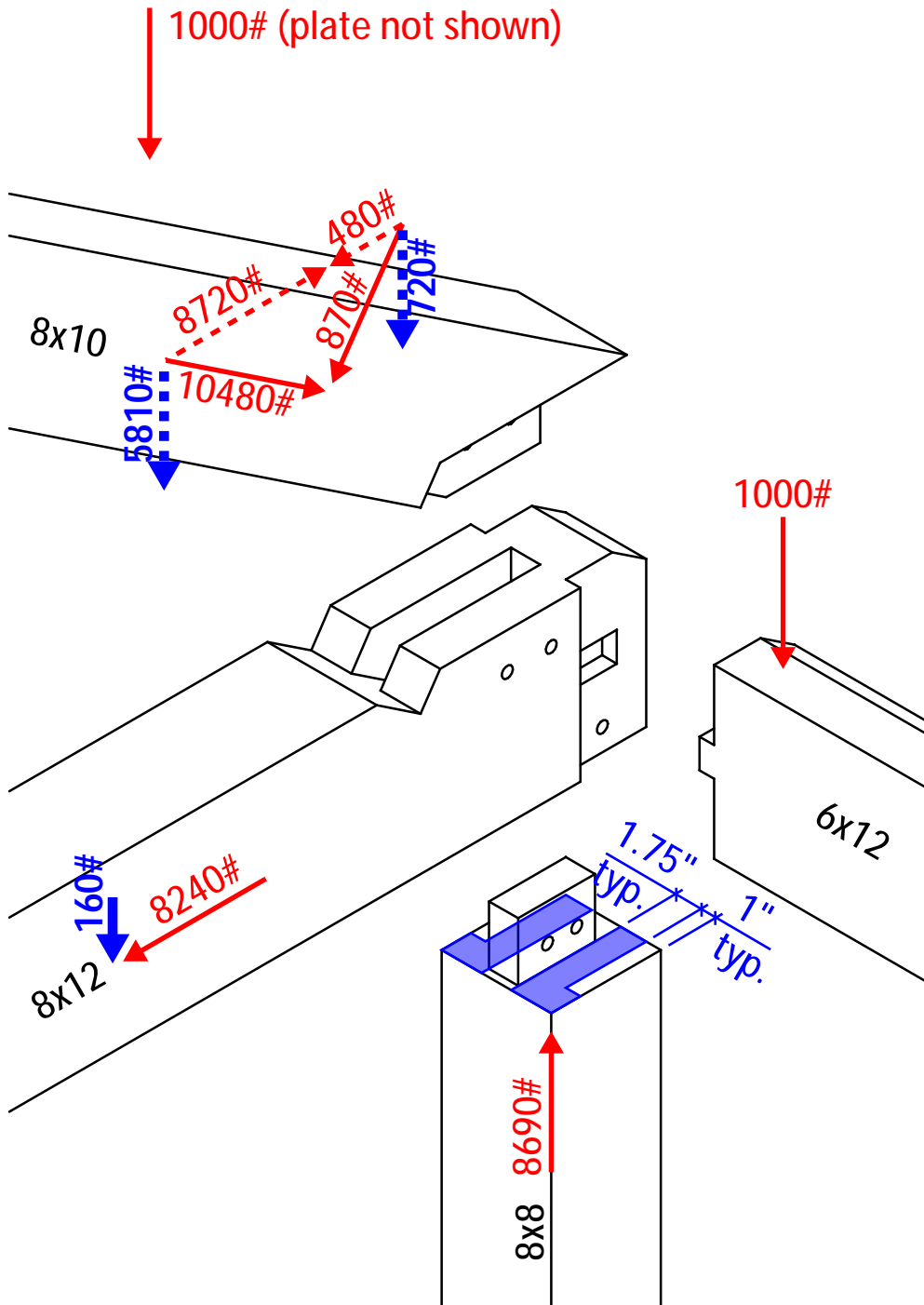

$$f_c = \frac{C}{A} = 221 \text{ psi}$$

$$C = 5,810\# + 720\# + 160\# = 6,690\#$$

$$A = 30.3 \text{ in}^2$$

F'_c

$$= \min. \begin{cases} F'_{c \perp \text{tie}} = 625 \text{ psi} \\ F'_{c \text{ post}} = 1,000 \text{ psi} * 1.15 = 1,150 \text{ psi} \end{cases}$$

$$= \boxed{625 \text{ psi} > 221 \text{ psi} \therefore \text{OK}}$$

Thank You

Questions?
Comments?